

VARISTAR Cooling unit SHX 30

Instruction Manual

60130-716

- Original instruction manual -



Product number:

62139-097

Produced by

nVent Schroff

Langenalber Str. 96 - 100

75334 Straubenhardt, Germany

The details in this manual have been carefully compiled and checked - supported by certified Quality Management System to EN ISO 9001/2000

The company cannot accept any liability for errors or misprints. The company reserves the right to amendments of technical specifications due to further development and improvement of products.

Copyright © 2013

All rights and technical modifications reserved

1	Safety	5
1.1	General information regarding safety	5
1.2	Warning notices	6
1.3	Safety of personnel	7
1.4	Intended use	8
1.5	Terms of warranty	8
1.6	Installation site	9
1.7	Safety instructions for transport	9
1.7.1	General information	9
1.8	Safety instructions for set-up	10
1.9	Safety instructions for maintenance	11
1.10	Disclaimer	11
2	Description / Overview	12
2.1	General information	12
2.2	Variants	12
2.3	Mode of operation	13
2.4	Air circuit	14
2.5	Water circuit	14
2.6	Control method	15
2.7	Alarms	16
2.8	Incorrect use	16
3	System Layout	18
3.1	Overview	18
3.2	Connections	20
3.3	Electrical box	22
3.4	Schematic system diagram	23
3.5	Function overview	24
3.6	Symbols / labels on the unit	25
4	Components	26
4.1	Control valve	26
4.2	Control unit	27
4.3	Interface board	28
4.4	Fuse board	30
4.5	Basic electronic system	31
5	Setting Up	32
5.1	General information	32
5.2	Transport and packaging material	34
5.3	Start-up	34
5.4	Installation	35
5.5	Connections	35
5.6	Electrical connection	37
5.7	Antifreeze and anti-corrosion agents	39
5.8	Adjustments	40

5.9	Venting	41
5.10	Removal/installation	44
6	Operation	45
6.1	General information	45
6.2	Adjustments	45
6.3	Switching off the unit	46
6.4	Control unit	47
6.4.1	General information	47
6.4.2	Activating/deactivating functions	48
6.4.3	Selecting and setting values	48
6.4.4	Program overview	49
6.4.5	Screen contents and descriptions	50
7	Maintenance.....	51
7.1	General information	51
7.2	Maintenance plan	53
7.3	Replacement	54
7.3.1	Fans	54
7.3.2	Actuator of the control valve	55
7.3.3	Temperature sensor	60
7.3.4	Replacement of other components	60
7.4	Antifreeze and anti-corrosion agents	61
7.5	Cooling module	62
7.5.1	Rinsing process	62
8	Troubleshooting	64
8.1	General information	64
8.2	Electrical connection	65
8.3	Unit-specific	65
8.4	Control unit	66
9	Disconnecting the device	68
9.1	General information	68
9.2	Dismantling	68
9.3	Transport and storage	69
9.4	Recycling	70
10	Technical Data	71
11	Spare Parts	74

1 Safety

1.1 General information regarding safety

Personnel in charge of carrying out work on the unit or system must have read and understood this manual and in particular the section on safety.

If necessary, in-house instruction should be provided, taking into account the technical qualifications of the personnel concerned.

Certain components have additional warning plates or labels to enable safer operation. Plates or labels must not be covered or removed.

Observe all safety instructions. Observation of these instructions is in the interest of personal safety.

The relevant accident prevention regulations as well as other generally recognised regulations concerning workplace health and safety must be observed.

The manual must be stored so that it is easily available at any time. It must be complete, kept close to the machine and must be available to all authorized persons.

1.2 Warning notices

Explanation of warning notices used in this manual:

 **DANGER**

Short description of danger

The signal word DANGER identified an immediately threatening danger.
Any non-adherence will result in most serious injuries or death.

 **WARNING**

Short description of danger

The signal word WARNING identified a potential danger.
Any non-adherence may result in most serious injuries or death.

 **CAUTION**

Short description of danger

The signal word CAUTION identified a potential danger.
The non-adherence may result in minor to medium injuries.

 **Notice**

Short description

The signal word Attention identifies a potential risk of property damages.
The non-adherence may cause damages at the unit or at the plant.

 **Note**

The signal word Note identifies further information on the unit or about its use.

1.3 Safety of personnel

Avoid any working practice that:

- endangers the health and safety of the user or third parties,
- presents a danger to the unit or system or other property,
- impairs the safety or functionality of the unit or system,
- does not comply with the safety instructions.

Maintenance and service should be performed only by suitably qualified persons who are familiar with the unit and who have been informed concerning the potential hazards.



WARNING

Danger for persons!

There is an increased risk of injury if the safety devices (e.g. fuses) are rendered inoperative. Do not remove or deactivate any safety devices.

- Check the safety devices daily for correct operation.
- Malfunctions and defects concerning the safety devices must be reported immediately to the after-sales service.
- The housing must be closed during the operation and may be opened only to rectify malfunctions or to perform maintenance tasks.
- Repairs to pipe systems and tanks may only be carried out when the system is depressurised.
- When handling chemicals, observe the applicable safety data sheets and disposal instructions that are provided by the suppliers, as well as any relevant local safety regulations. Wear protective clothing!

Any safety devices that have been removed for set-up, maintenance, or repair purposes must be reinstalled and checked for correct operation immediately upon the completion of the maintenance and repair work.

In the above case, particular attention must be paid to the general accident prevention and safety regulations.

1.4 Intended use

The unit or the system is intended solely for the application outlined in the “Description/Overview” section and only with the components supplied and approved.

Using the unit for purposes other than those mentioned above is considered contrary to the intended use. The manufacturer cannot be held liable for any damage resulting from such use. The risk of such misuse lies entirely with the user.

1.5 Terms of warranty

The manufacturer is not liable for damage resulting from improper use, the failure to observe this manual, the employment of insufficiently qualified personnel, or unauthorised modifications. In these cases the manufacturer’s warranty is rendered void.

! Notice

Unit function is affected when using incorrect spare parts!

When using components which have not been approved, correct operation can no longer be guaranteed. Only use spare parts approved by the after-sales service.

! Notice

Caution - Loss of warranty!

The use of media that are not approved may result in damage to the unit or to the system. The warranty will be rendered void. The same shall apply if different media are mixed.

Use only media that have been approved by the manufacturer.

▶ Note

Removing type plates will make the warranty claim expire.

▶ Note

The warranty will be rendered void if seals are broken without authorisation.

1.6 Installation site

When selecting an installation site, observe the following instructions:

- Keep the specified escape routes clear.
- Ensure firm support and a horizontal position of the unit.
- Comply with the data stated in the “Technical Data” section concerning the ambient temperature for operation, transport, and storage when the unit is completely empty.
- Ensure sufficient space for operating, maintaining, and cleaning the unit.
- Keep the air inlets and outlets free.

Comply with the relevant technical and building regulations.

Lay the hoses and electrical cables so that there is no danger of tripping and that they are protected from damage.

When selecting an installation site, the applicable safety regulations and manufacturer instructions concerning any substances that are used for, or located near, the machine must be observed.

1.7 Safety instructions for transport

1.7.1 General information

WARNING

Danger for persons!

Increased risk of injuries through improper transport.

The transport of the unit should be carried out only by suitably qualified persons who are familiar with the unit and who have been informed as to potential hazards.

Notice

Damaging of unit!

Damage due to improper transport.

- Make sure to follow signs (if attached) at unit when transporting unit.
- Transport units with suitable lifting gear only.
- Transport the unit only when it is empty.
- Transport on suitable and secured transporting pallet.

WARNING

Danger of overturning!

Due to the slim set-up of the unit, there is a higher risk of injury when the unit tips over.

Ensure that the unit is sufficiently secured during the transport.

1.8 Safety instructions for set-up

 **WARNING**

Danger through faulty commissioning!

There is an increased risk of injury to persons who perform tasks for which they are not suitably qualified or trained.

- The commissioning of the system shall only be carried out by persons familiar with the system and instructed with respect to dangers and risks involved, also having the required qualifications.
- Fulfil all safety-relevant conditions before commissioning.
- The location of the unit or of the system must correspond to the regulations according to Chapter "Safety, Choice of Location".

 **Notice**

Damage to components!

Danger of damage due to improper operation. Observe the description of additional components, if included.

 **Note**

Check all hoses and hose connections for leaks when commissioning the unit.

1.9 Safety instructions for maintenance

WARNING

Carry out instructed maintenance works only!

There is an increased risk of injury to persons who perform tasks for which they are not suitably qualified or trained.

- Maintenance works should be carried out only by suitably qualified personnel who are familiar with the unit and who have been informed as to potential hazards.
- Repairs to pipe systems and tanks may only be carried out when the system is depressurised.

WARNING

Connections alive!

Negligence can lead to electric shock.

Observe the following points when carrying out maintenance work on the electrical system:

1. Disconnect the unit from the power supply in order to deenergise it.
2. Secure the unit so that it cannot be switched on again accidentally.
3. Check whether the unit is properly disconnected from power and absolutely voltage-free
4. Earth and short-circuit the unit.
5. Cover any adjacent live parts and secure the danger area.

Notice

Damage to electronic components!

Take suitable measures (ESD protection measures) to prevent the electronic components from being damaged due to electrostatic discharge.

1.10 Disclaimer

Schroff shall not be held liable for any errors that may be included in this documentation. Liability for direct and indirect damage that occurs in connection with the supply or use of this documentation is excluded to the extent permitted by law.

Schroff reserves the right to change this document, including the disclaimer of liability, at any time and Schroff shall not be liable for the potential consequences of these changes.

2 Description / Overview

2.1 General information

The cooling modules that are described in this instruction manual are part of a cooling unit for the Schroff VARISTAR cabinet platform. In combination with the corresponding VARISTAR cabinets, the cooling units are used to set up an enclosure.

► Note

For the start-up of the cooling system, the cooling module must be connected to an external re-cooling system (e.g. water chiller).

The unit is suitable for the use of water-glycol mixtures (33% glycol max.).

The power supply is ensured via a power supply unit. The power supply unit transforms the mains voltage (AC, alternating voltage) into a direct voltage (DC) and it supplies various components with power, including the control system and fans.

Since the fans are intended for a supply voltage of 48 V (DC), the cooling module can also be used in telecommunications environments.

► Note

See the circuit diagram.

2.2 Variants

The cooling modules are supplied as part of a Schroff VARISTAR cooling unit. The variants and dimensions of the cooling units are configured based on the customer requirements and VARISTAR cabinets that are used.

The following variants of the cooling modules are available:

- 60714-067: Cooling module, water connection at the bottom
- 60714-068: Cooling module, water connection at the bottom, redundant power supply
- 60714-077: Cooling module, water connection at the top
- 60714-078: Cooling module, water connection at the top, redundant power supply

► Note

- Cooling modules with a redundant power supply are equipped with two power supply units and mains power inputs. They can be supplied with power via two independent mains power sources.
- In the case of cooling modules with a water connection at the top, the condensate outlet is also located at the top. These cooling modules are equipped with an integrated condensate pump.

2.3 Mode of operation

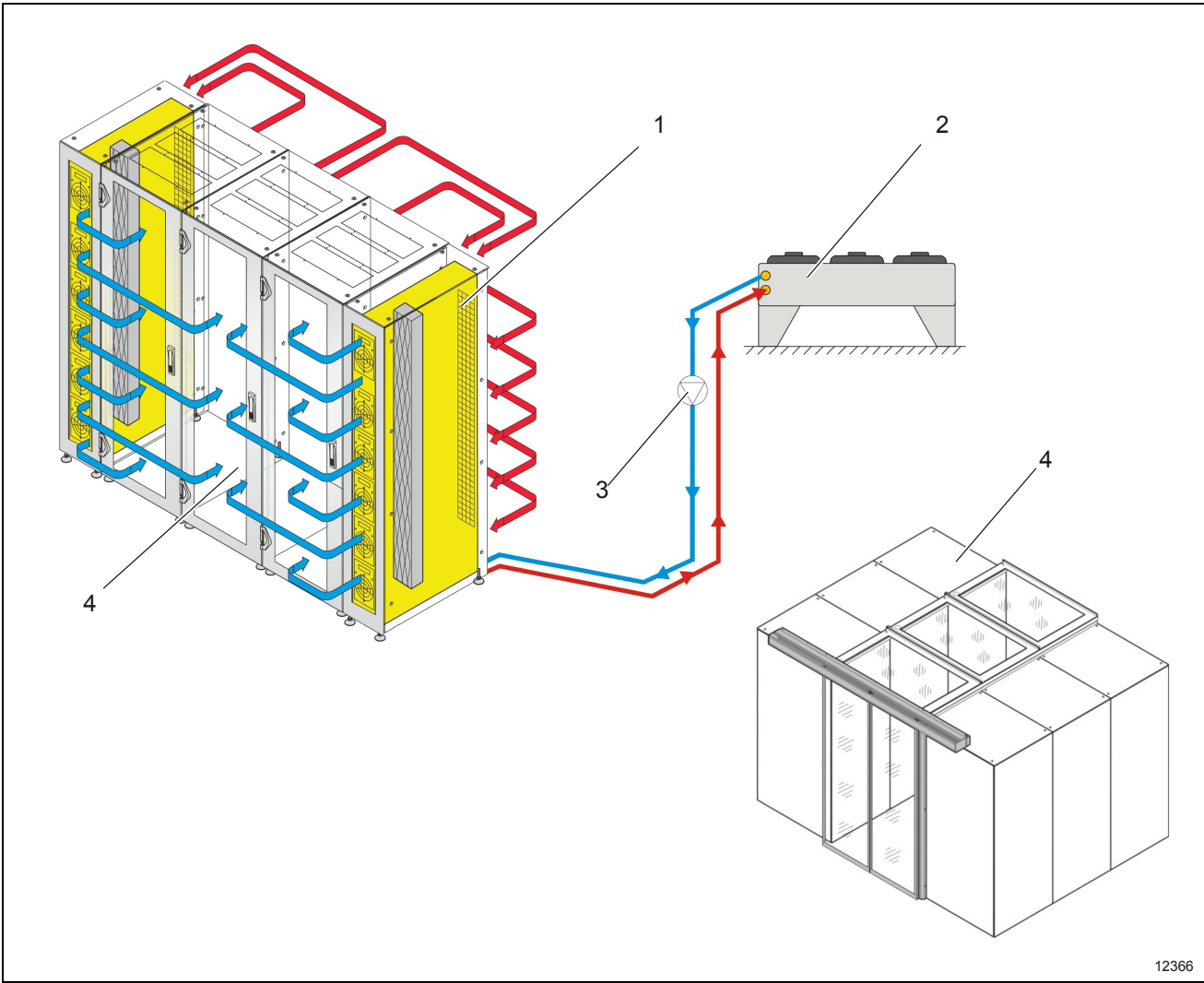

Fig. 1: Mode of operation of the cooling module (principle)

- | | | | |
|---|---------------------|----|---------------------------------------|
| 1 | Cooling module | 3 | Pump *) |
| 2 | External recoler *) | 4 | Enclosure |
| | | *) | (not included in the scope of supply) |

The cooling units are positioned between the VARISTAR cabinets in an enclosure. The fans of the cooling unit suck the warm air in at the back and guide it through an air/water heat exchanger. The air will be cooled and blown out at the front. The cooling system comprises an air circuit and a water circuit. In the air/water heat exchanger, the thermal energy of the warm air is transferred to the water. The air/water heat exchanger is connected to an external recoler (not included in the scope of supply) that cools the heated water.

2.4 Air circuit

Example "cold aisle containment":

The fans of the cooling unit withdraw the heated air from the room and guide it through an air/water heat exchanger. During this process, the thermal energy is transferred to the water circuit. The cool air then fed into the cold aisle. A demister removes any condensate that may have formed.

The condensate is collected in a condensate tray and discharged via the condensate pipe at the top or bottom of the cooling module.

The fans that are distributed vertically over the entire cabinet height ensure a homogeneous temperature stratification. As a result, the temperature difference can be reduced and the efficiency of the cooling system can be increased.

Components of the air circuit:

- Air/water heat exchanger
- Demister
- Fans
- Temperature sensor (air)

2.5 Water circuit

The chilling medium of the external recooling (not included in the scope of supply) flows through the air/water heat exchanger of the cooling modules and heats up. Then, it flows back into the recooling. The temperature is controlled via an electric powered control valve that controls the chilling medium flow based on the required cooling power.

Components of the water circuit:

- Control valve
- Air/water heat exchanger
- Water temperature sensor

► Note

- The control valve in the water circuit of the cooling module is a straight-way valve (2-way valve). The advantage of this solution is that only the quantity of water that is required for cooling flows through the air/water heat exchanger. The circulation pump can be operated with constant pressure and a variable quantity of water.
- For cooling systems that required three-way functionality, the cooling module can also be supplied with a 3-way valve upon request.

2.6 Control method

The fans and the control valve of the water circuit are actuated by a closed loop and open loop control unit. A closed loop control circuit controls the flow of water through the air/water heat exchanger as a function of the air outlet temperature of the cooling module.

The cooling module has four temperature sensors; two in the air outlet at the top and at the bottom as well as two temperature sensors in the air inlet at the top and at the bottom. In addition, an external temperature sensor (option) can be connected. The output signal of these sensors is used as the reference value for the control system. The reference sensor can be selected in the settings menu.

In order to compensate for temperature stratifications, the air outlet temperature is measured by two temperature sensor on different levels. The average value of these temperature sensors is the control variable for the opening characteristics of the control valve.

Under normal operating conditions, the fans run at constant speed.

In order to ensure sufficient air circulation in the cabinet, the factory setting is 80% of the nominal speed. The operator can set this value within a range of 30% to 100% via the settings menu.

If the set temperature is exceeded by 4°C (factory setting), the system will switch to maximum cooling power, i.e. the control valve will open by 100% and the fan speed will be increased to 100% of the nominal speed.

If the actual value falls below the set temperature by 3°C, the normal mode will be resumed.

► **Note**

The control characteristic is defined at the factory. However, it can be changed and adapted by the service department of Schroff or by a licensed service partner.

2.7 Alarms

The electronic control system can detect various malfunctions (e.g. cable break of a temperature sensor, temperatures exceeding the limit values) and indicate them via the display or interface.

In order to issue a visual alarm, there is an LED (red) above the control unit on the cooling module.

The following error messages will be signalled:

- The actual fan speed is below the minimum speed.
- Failure of a fan.
- Cable break of a temperature sensor.
- Supply voltage of the electronic control system: undervoltage.
- Faulty Modbus communication.
- Failure of power supply unit 1 or 2.
- The actual cooling water temperature is above the limit value.
- Malfunction of the condensate pump (option).
- Door opened (option)

► **Note**

In the event of a malfunction, refer to the "Troubleshooting" section.

2.8 Incorrect use

In general:

any incorrect use is classed as 'not for the intended purpose'. The manufacturer cannot be held liable for any damage resulting from such use. The risk of such misuse lies entirely with the user. Moreover, intended use of the unit also involves use in accordance with the applicable international and national safety instructions as well as the safety instructions in the manual.

Amongst others, the unit is **NOT** intended for the following applications:

- Outdoor use.
- Non-compliance with the permissible technical data. See the "Technical data" section.



3 System Layout

3.1 Overview

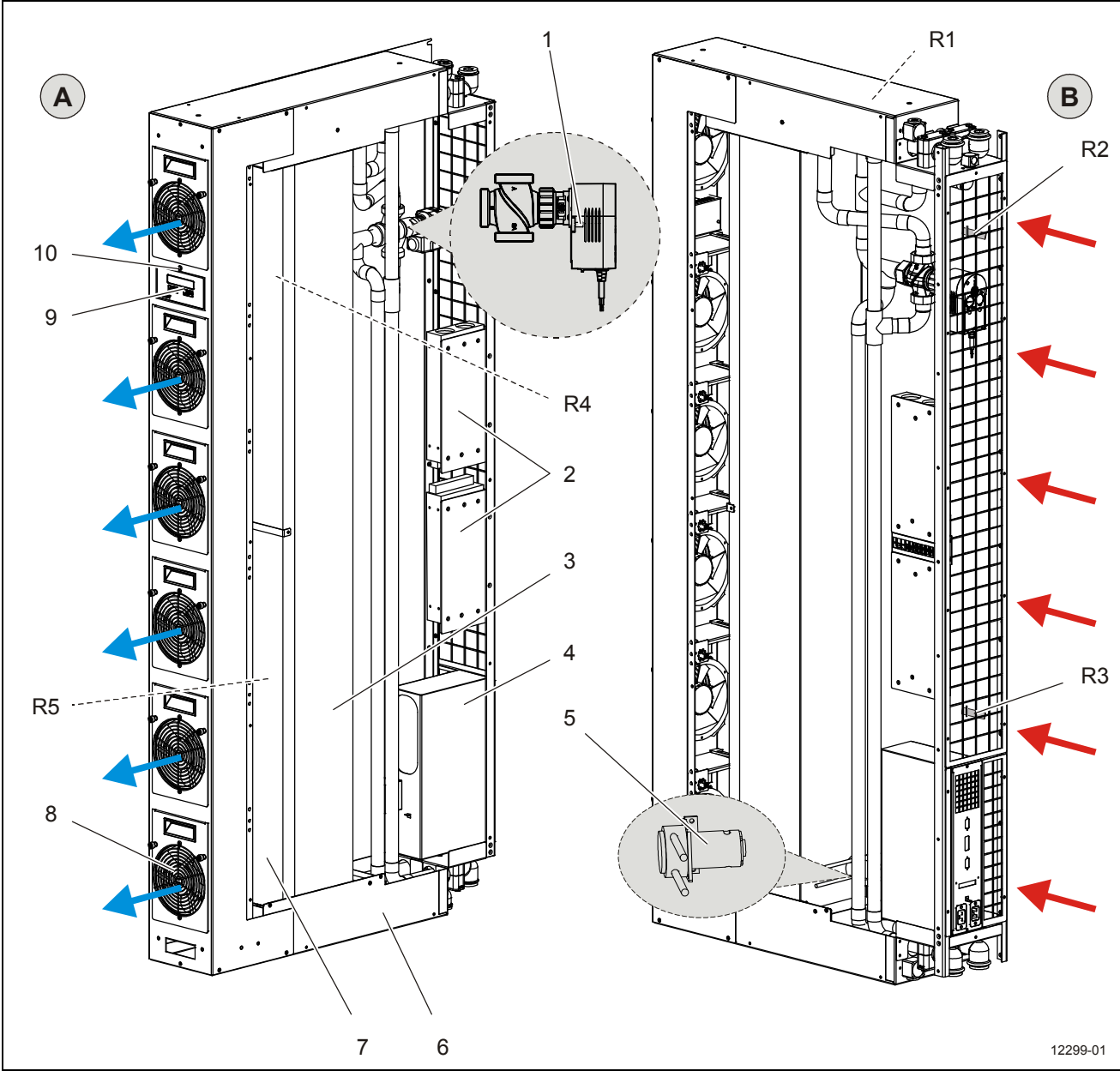

Fig. 2: Heat exchanger

- 1 Control valve with actuator
- 2 Power supply unit
- 3 Heat exchanger (air/water)
- 4 Switch box
- 5 Condensate pump with float switch (option)
- 6 Condensate tray
- 7 Demister
- 8 Fan
- 9 Control unit (display and operating unit)
- 10 LED (red)
- flashing: malfunction *)

Views

- A Front view
- B Back view

Temperature sensor

- R1 Chilling medium inlet
- R2 Air inlet (top)
- R3 Air inlet (bottom)
- R4 Air outlet (top)
- R5 Air outlet (bottom)

► Note

- *) In the event of a malfunction, refer to the "Troubleshooting" section.

3.2 Connections

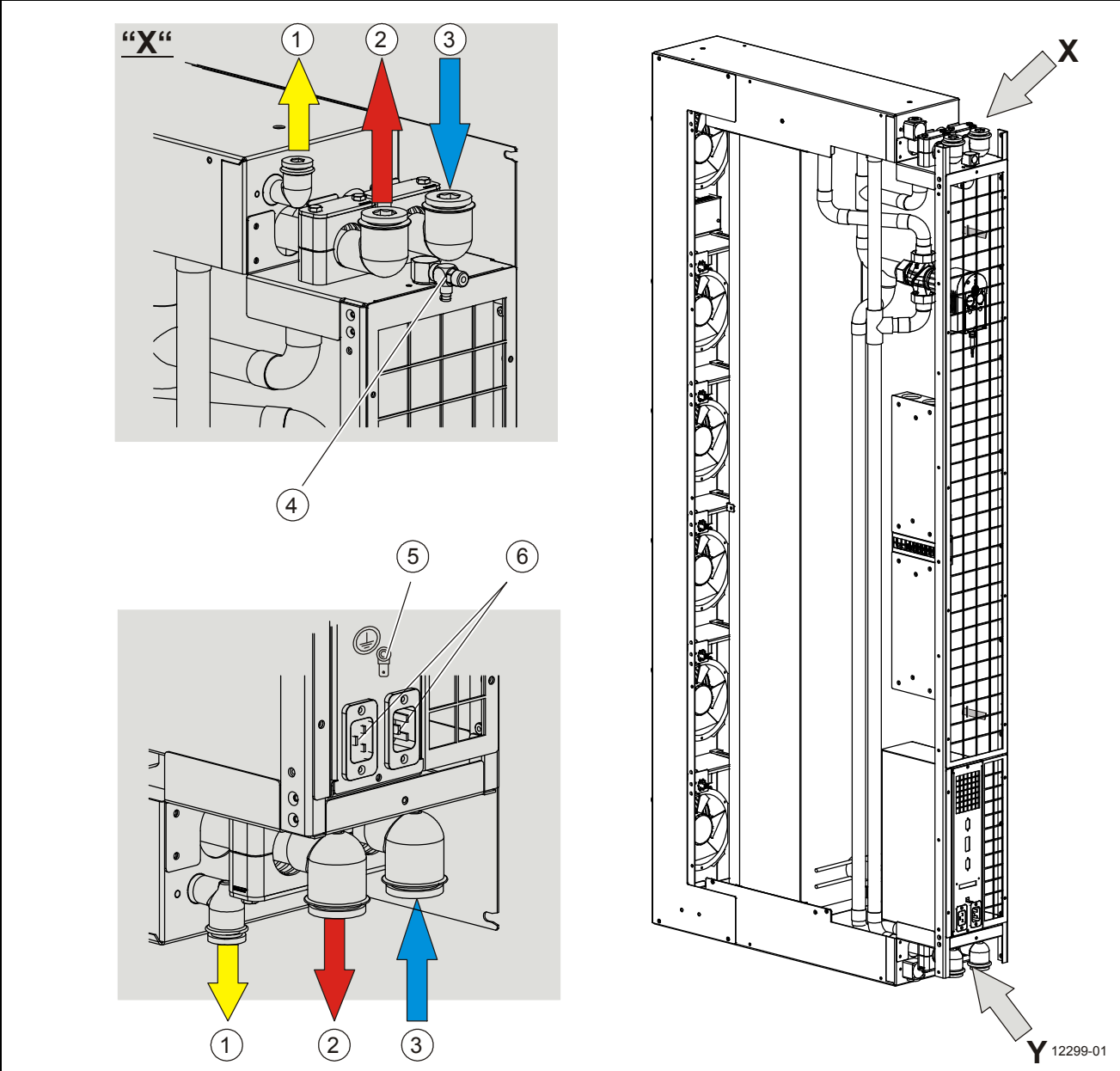

Fig. 3: Connections

1	Condensate outlet	X	Connectors (top)
2	Chilling medium outlet	Y	Connectors (bottom)
3	Chilling medium inlet		
4	Venting point		
5	Protective earth		
6	Power supply connector (redundant power supply)		

► Note

- The chilling medium connectors are located at the top and bottom of the unit (back). Connectors that are not required must be sealed with a blind plug.
- In the case of cooling modules with a water connection at the top, the condensate outlet is also located at the top. These cooling modules are equipped with an integrated condensate pump.
- Connect the condensate outlet with a sufficient gradient to the wastewater system.
- Cooling modules with a redundant power supply are equipped with two power supply units and mains power inputs. They can be supplied with power via two independent mains power sources.

3.3 Electrical box

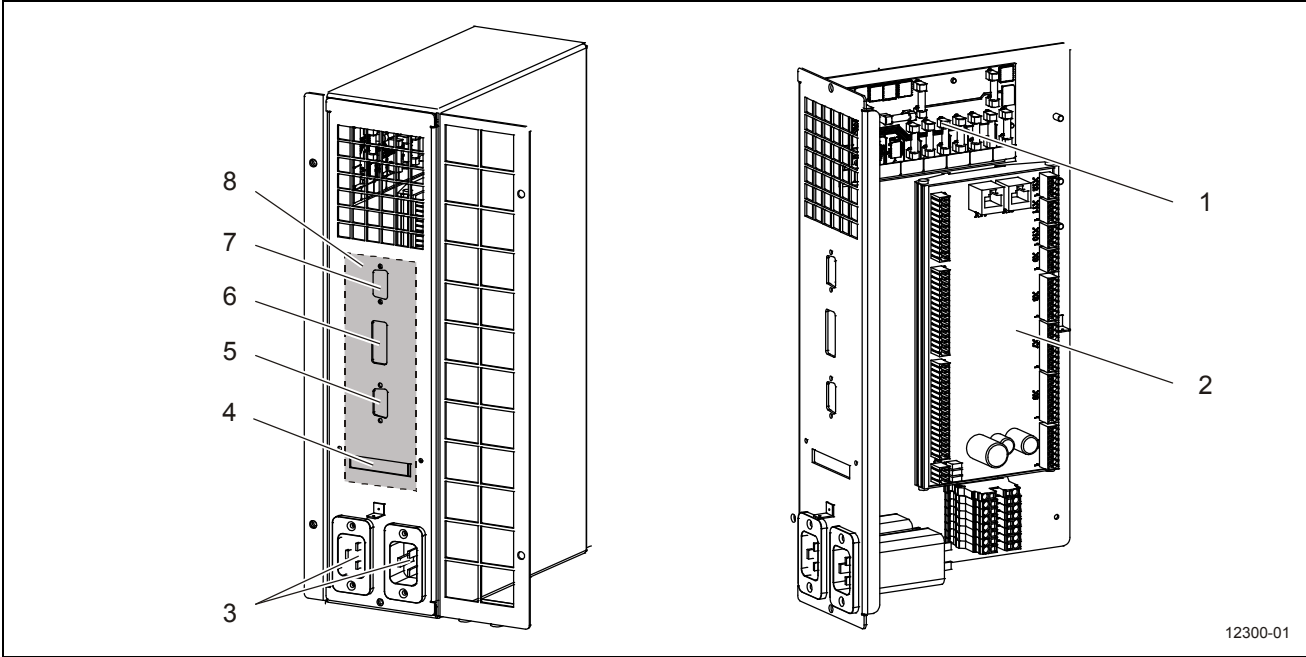

Fig. 4: Electrical box

- | | | | |
|---|---|---|--|
| 1 | Fuse board (circuit board with miniature fuses) | 5 | Data interface (RS232, SUB-D, 6 pin) |
| 2 | Basic electronic system, type TIOM 112 (I/O unit) | 6 | Data interface (RS485, 2x RJ45) |
| 3 | Power supply connector (optionally with a second power supply unit) | 7 | Connector for connecting the external temperature sensor |
| 4 | Interlock-interface (DI/DO, 10 pin) | 8 | Interface board |

► **Note**

Follow the instructions given in the circuit diagram.

3.4 Schematic system diagram

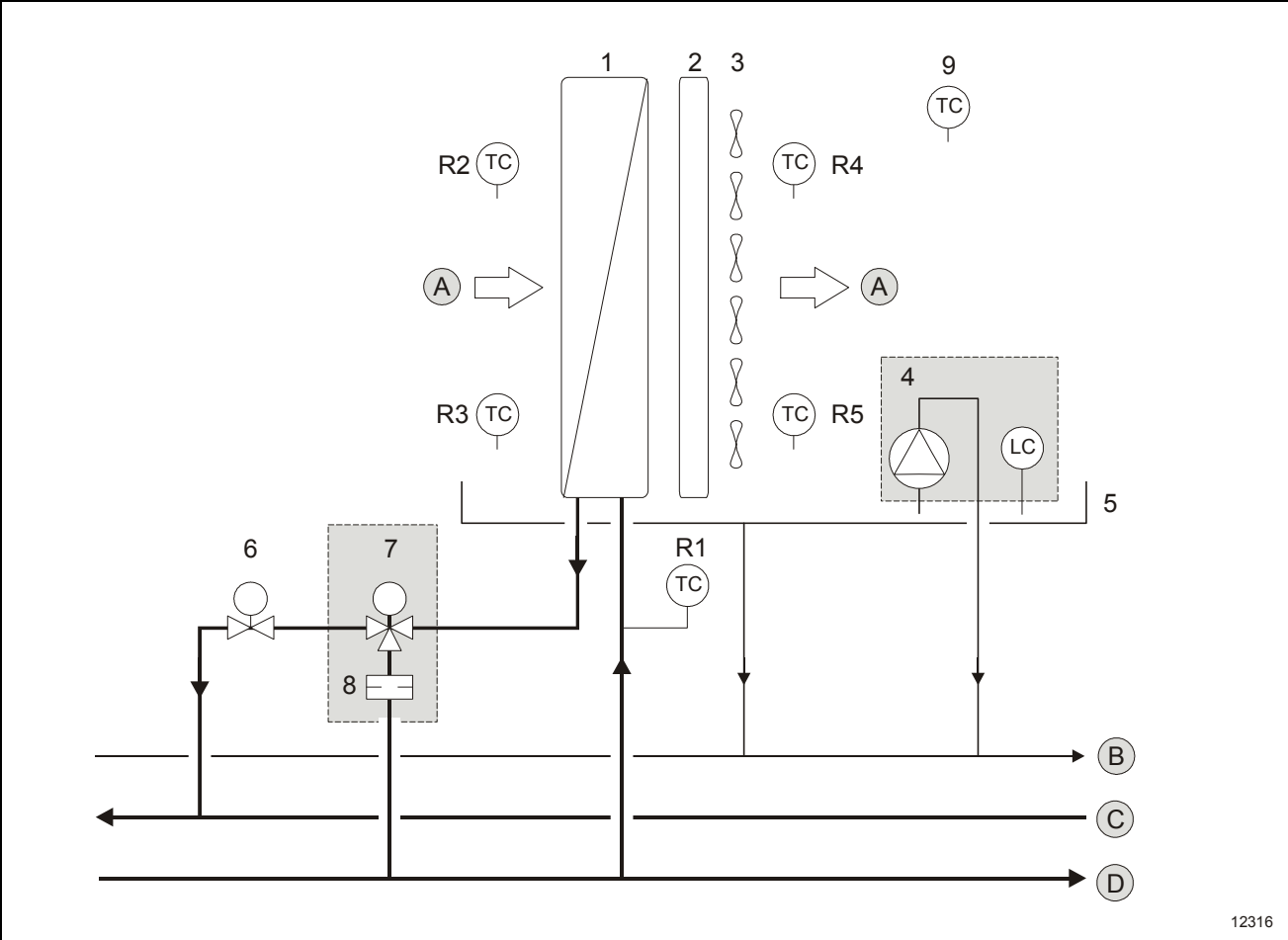

Fig. 5: Schematic system diagram

- 1 Heat exchanger (air/water)
- 2 Demister
- 3 Fan
- 4 Condensate pump with float switch (option)
- 5 Condensate tray
- 6 Control valve (two-way valve) with actuator
- 7 Control valve (three-way valve) with actuator (option)
- 8 Orifice plate (option)
- 9 External temperature sensor (option). Connection: customer-specific

- A Air flow (inlet, outlet)
- Connectors**
- B Condensate outlet
 - C Chilling medium outlet
 - D Chilling medium inlet
- Temperature sensors**
- R1 Chilling medium inlet
 - R2 Air inlet (top)
 - R3 Air inlet (bottom)
 - R4 Air outlet (top)
 - R5 Air outlet (bottom)

► **Note**

Follow the instructions given in the circuit diagram.

3.5 Function overview

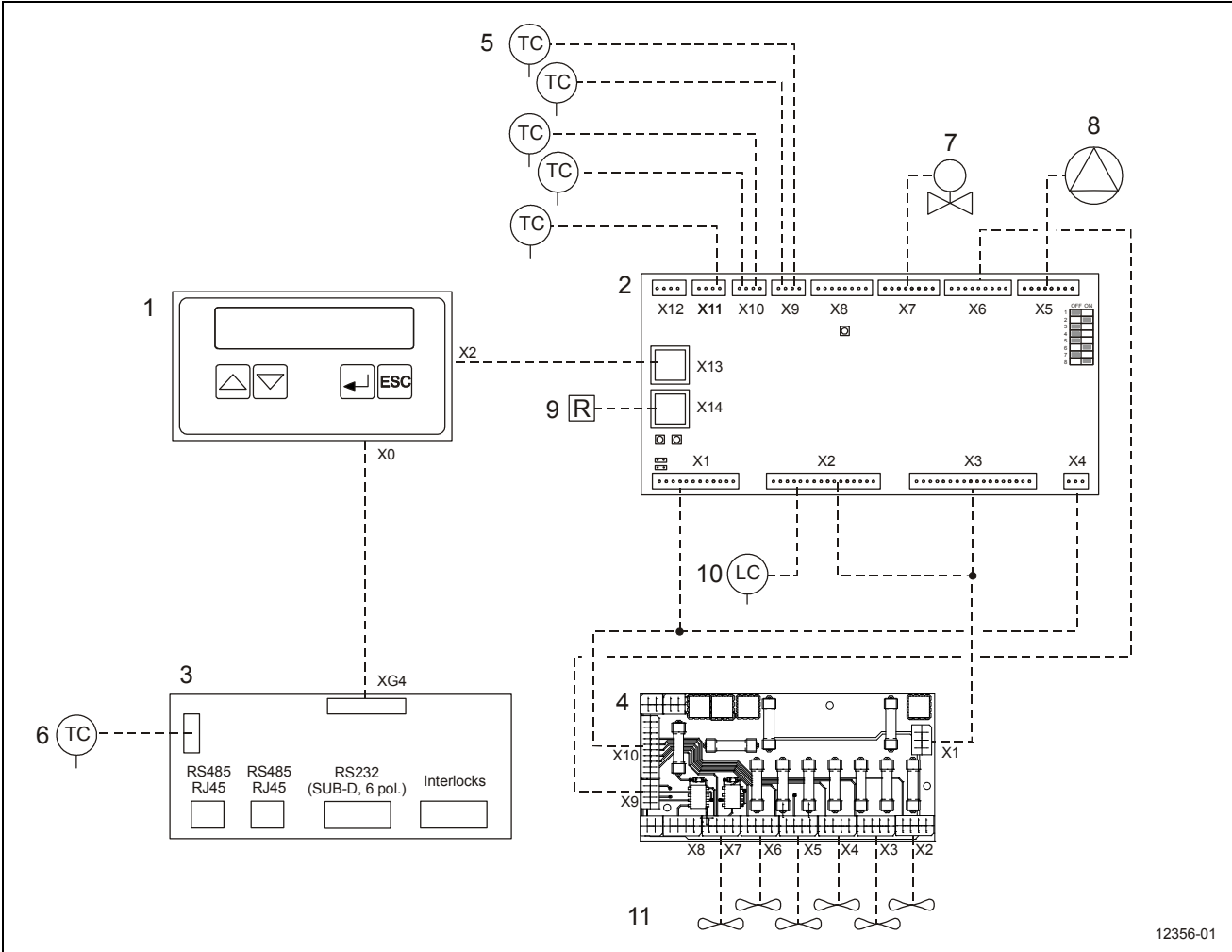

Fig. 6: Function overview (principle)

- | | | | |
|---|---|----|----------------------|
| 1 | Control unit (display and operating unit) | 7 | Control valve |
| 2 | Basic electronic system (I/O unit) | 8 | Condensate pump |
| 3 | Interface board | 9 | Terminating resistor |
| 4 | Fuse board (circuit board with miniature fuses) | 10 | Float switch |
| 5 | Temperature sensor (internal) | 11 | Fan |
| 6 | Temperature sensor (external) | | |

► **Note**

Follow the instructions given in the circuit diagram.

3.6 Symbols / labels on the unit

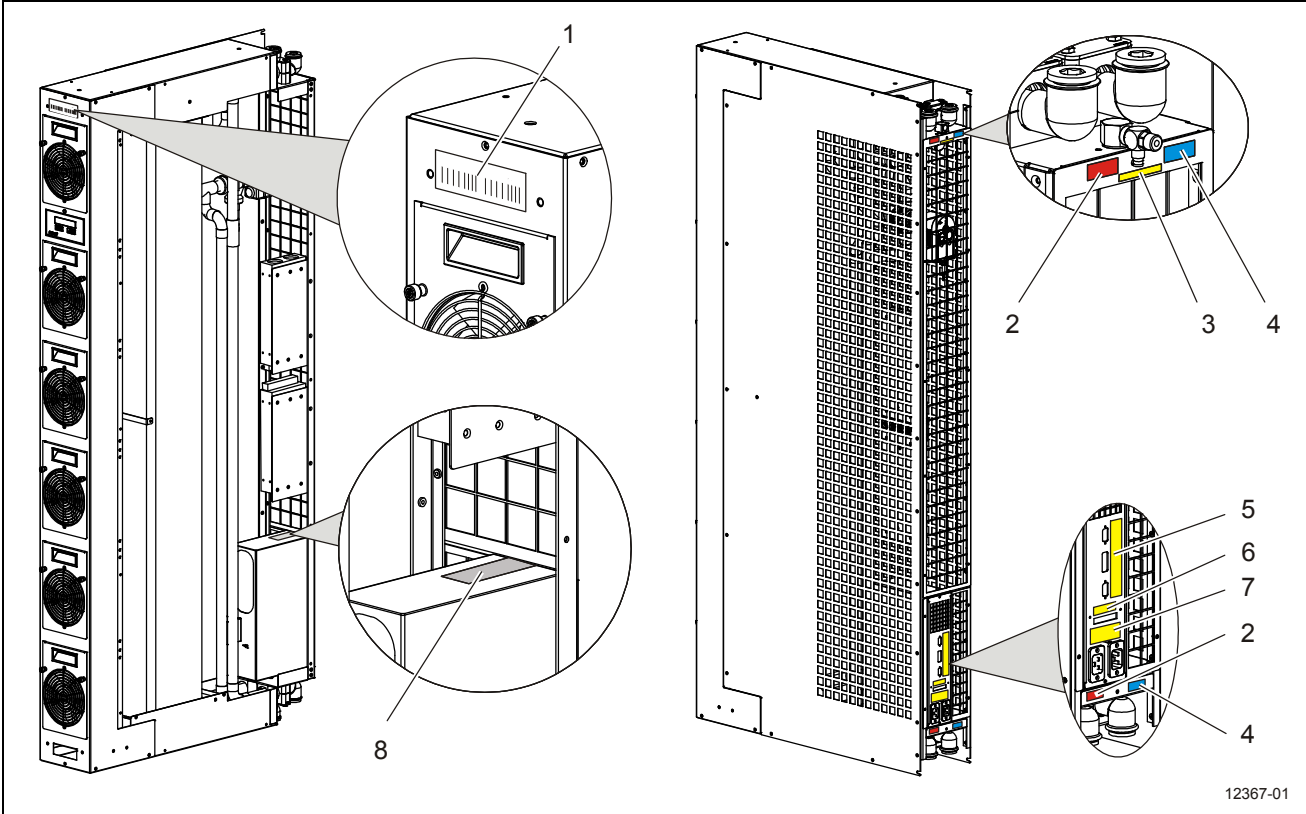

Fig. 7: Labels on the unit

	Label	Description
1		Bar code
2		Chilling medium outlet
3		Venting point
4		Chilling medium inlet
5		Information concerning the interface (RS232, RS485) and connection of the external temperature sensor
6		Connection point for I/O signal <ul style="list-style-type: none"> Interlock-interface (DI/DO, 10 pin)
7		Power supply connector (redundant power supply) <ul style="list-style-type: none"> A Connector 1 B Connector 2 (redundant)
8		Type plate of the unit

4 Components

4.1 Control valve

Control valve for the continuous control of cooling media in loops.

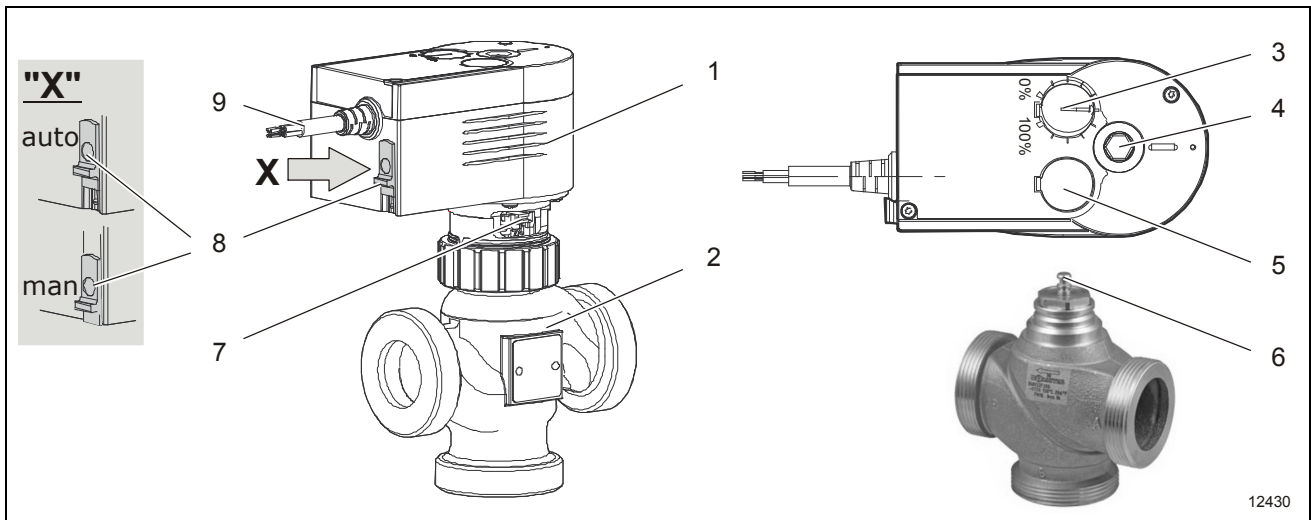

Fig. 8: Actuator, control valve (Example)

- | | | | |
|---|--|---|--------------------------------------|
| 1 | Actuator | 6 | Valve spindle |
| 2 | Control valve | 7 | Locking mechanism (engaging) |
| 3 | Display for opening degree of control valve (0-100%) | 8 | Selector switch (Automatic / Manual) |
| 4 | Adjusting screw of actuator | 9 | Connection cable |
| 5 | Cover cap of DIP switch | | |

The actuator is directly plugged onto the control valve and fixed with a nut. The connection of the drive with the valve spindle is done automatically.

The valve is closed with the valve spindle pulled out.

► Note

- The drive will move out during the first commissioning of the plant. The cap closes automatically when reaching the lower valve seat. The stroke of the valve is detected by the drive.
- The DIP switch is set ex works. Setting: see circuit diagram.

4.2 Control unit

Adjustments and adaptations concerning the cooling module can be performed via the control unit (display and operating unit). Under normal operating conditions, the display unit displays the actual value of the selected temperature sensor. The control unit is located at the front of the cooling module.

Apart from four membrane keys and display with 2 x 20 digits, the display and operating unit also includes the entire electronic control system. The electronic control system is connected to a remote I/O unit (basic electronic system) at the back of the cooling module via a CAN bus.

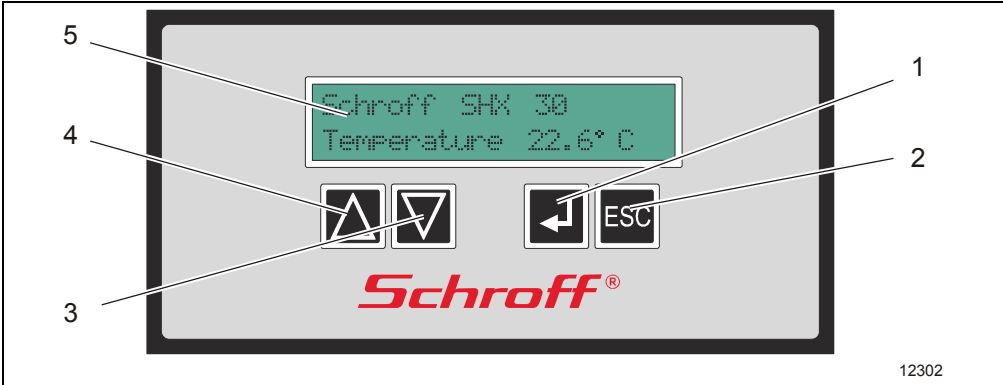

Fig. 9: Control unit (front view)

- 1 Confirmation key (Enter key)
- 2 Cancel key (ESC key)/backward key
- 3 Selection and setting key (down key)
- 4 Selection and setting key (up key)
- 5 Display

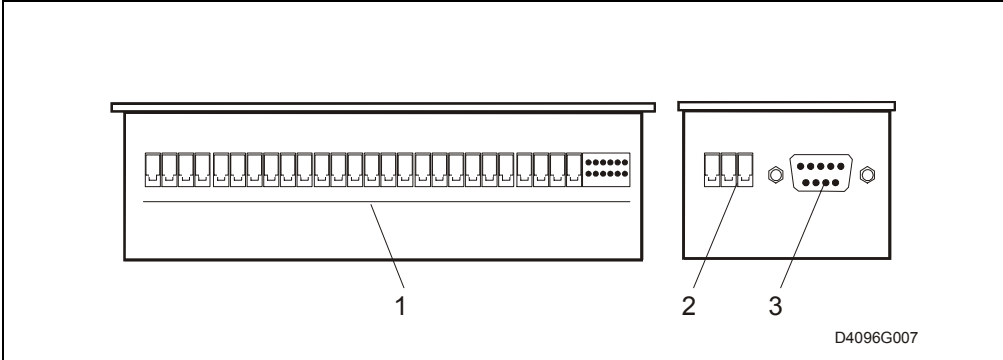

Fig. 10: Control unit (connections)

- 1 CAN interface - digital inputs / outputs (option)
- 2 Power supply
- 3 RS232/485 jack

4.3 Interface board

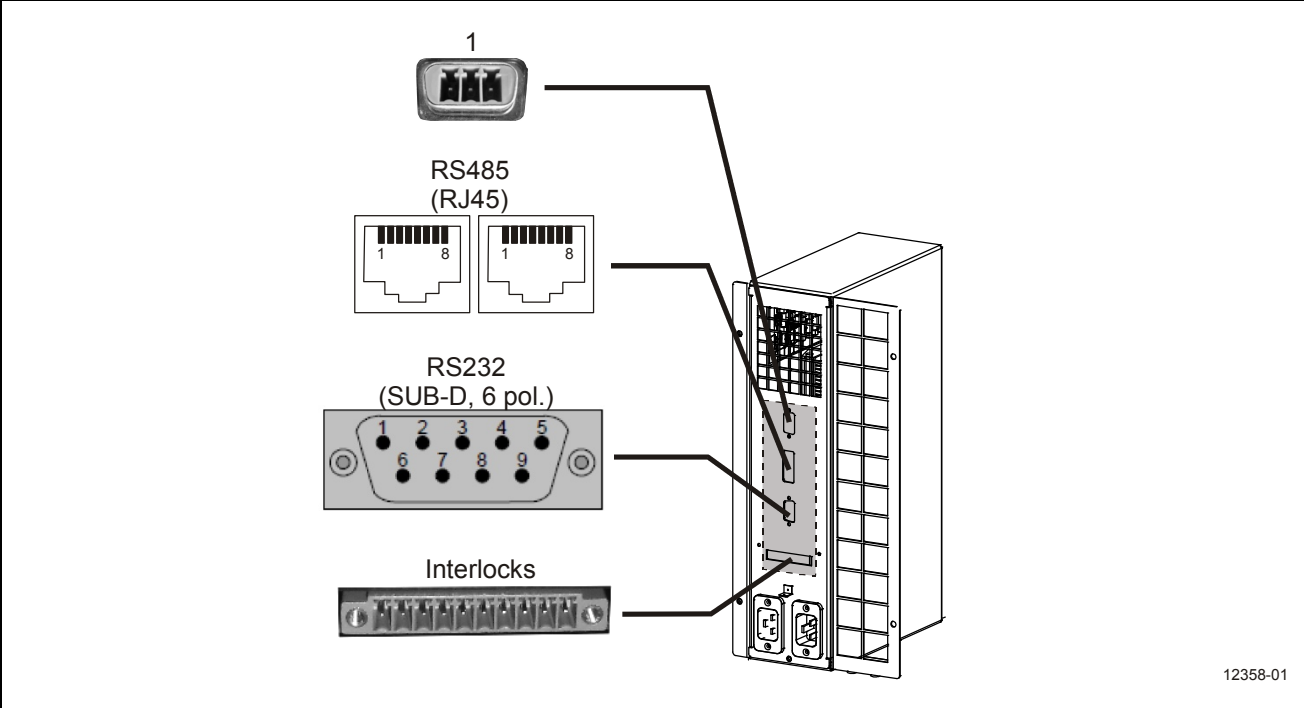

Fig. 11: Interface board

The interface board is a device interface and used for the connection of an external temperature sensor (1).

RS485:

The RS485 data interface (2x RJ45, female connector) is used for the communication between the cooling module and an external monitoring module via the Modbus protocol.

Pin	Name
4	B
5	A
6	GND

RS232, 6 pin:

The RS232 data interface (SUB-D, male connector) is used for the communication between the cooling module and an external monitoring module via the Modbus protocol. For service purposes, the interface is used for the firmware update of the control system.

Pin	Name
2	TxD
3	RxD
4	GND

Interlock, DI/DO, 10 pin:

The Interlock-interface serves to connect the door contact switch and as an output for 4 freely programmable fault relays.

Pin	Name
1	TK.1
2	TK.2
3	Out1.1
4	Out1.2
5	Out2.1
6	Out2.2
7	Out3.1
8	Out3.2
9	Out4.1
10	Out4.2

4.4 Fuse board

The fuse board is a circuit board that is equipped with miniature fuses and used for the actuation and protection of the fans.

The fans are actuated via the control unit and I/O unit (basic electronic system).

The power supply of the fuse board is ensured by power supply units.

In the event of a failure of the fans, it may be necessary to check and replace the miniature fuses.

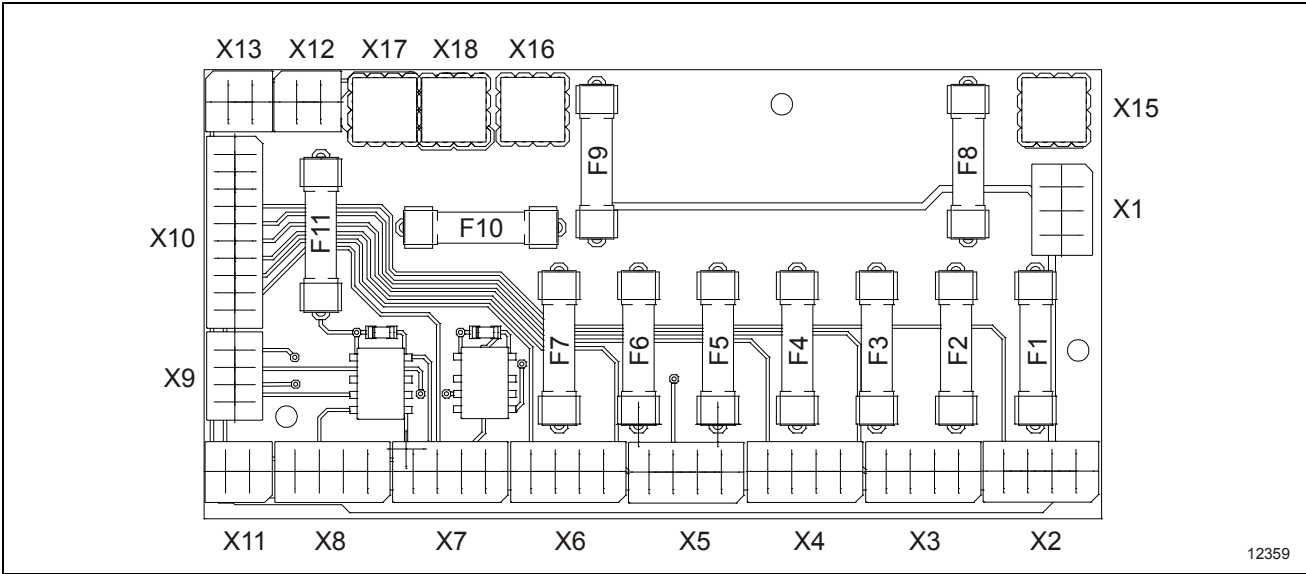

Fig. 12: Fuse board

Miniature fuse	Connector	Fan
F1	X2	1
F2	X3	2
F3	X4	3
F4	X5	4
F5	X6	5
F6	X7	6
F7	X8	7 (option)

► Note

Follow the instructions given in the circuit diagram.

4.5 Basic electronic system

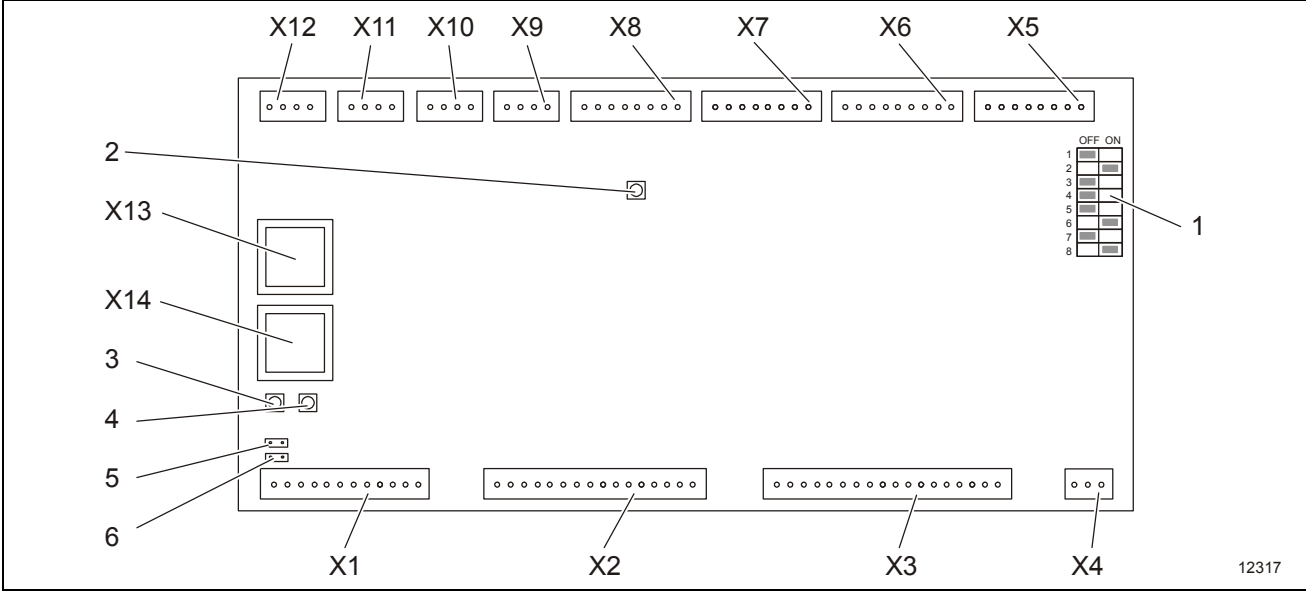

Fig. 13: Basic electronic system (example)

- 1 DIP switch (see the circuit diagram for setting information)
- 2 Pilot LED (CPU-K): LED flashes = processor active
- 3 Pilot LED (+24V-T): 24 V active on connector X13, X14
- 4 Pilot LED (RUN/ERR): CAN communication
 - LED lights green = normal state
 - LED lights red = communication problem
- 5 Jumper +24V - T
- 6 Jumper 0V - T

Connector	Description
X1	Digital inputs
X2	Digital inputs
X3	Digital outputs
X4	Power supply
X5	Digital outputs
X6	Analogue outputs
X7	Analogue outputs
X8	Analogue inputs
X9	Analogue inputs
X10	Analogue inputs
X11	Analogue inputs
X12	Analogue inputs
X13, X14	CAN bus

5 Setting Up

5.1 General information



WARNING

Danger of overturning!

Due to the slim set-up of the unit, there is a higher risk of injury when the unit tips over. Ensure that the unit is sufficiently secured during the transport.



Notice

Danger of damage due to condensation!

At temperatures below 15°C/59°F, condensation may form inside the unit and cause damage to the unit when it is switched on.

Prior to switching the unit on, ensure that the unit has acclimatised sufficiently.



Notice

Damage through dirt particles!

Dirt particles in customer-provided installations (e.g. pipes, hoses, ...) may lead to malfunctions or damage to the components or unit/system.

- Ensure that the customer-provided installations (e.g. pipes, hoses, ...) are free from dirt particles.
- If necessary, clean, rinse, or flush the customer-provided installations.



Notice

Risk of damage to components!

The medium that is to be connected (e.g. cooling water) can cause damage.

- Take suitable measures (e.g. leak sensors, automatic shut-off valves) in order to prevent damage to the neighbouring components in the event of a leak or defect.
- These measures depend on the installation site and the building-related conditions on site. They are in the area of responsibility of the fitter or system planner.

► **Note**

Optimum water quality for filling: information can be found in the "Technical Data" section.

► **Note**

- Only trained, specialised personnel is authorised to perform the set-up, start-up, completion, maintenance, and service of the units.
- Observe the "Safety" section.
- Comply with the national rules and regulations concerning occupational health and safety.

► **Note**

The storage or transport at ambient temperatures below 0°C/32°F require special measures in order to avoid frost damage.

- Observe the "Anti-freeze and corrosion protection" section.
- Transport the unit only without water.

For further information regarding connections, versions, pressure specifications, settings etc. please refer to the following chapters:

- Layout / System layout
- Components
- Maintenance
- Technical Data

as well as the instruction labels on the unit (if provided).

5.2 Transport and packaging material

The unit will be delivered on a special pallet.

Remove any transport material and packaging.

Dispose of the transport and packaging material in an environmentally-compliant manner and in accordance with the applicable local rules and regulations.

► Note

After unpacking, check the unit for signs of transport damage or other damage.

► Note

In order to avoid transport damage if the unit needs to be returned to the manufacturer, return the unit solely in its original packaging.

5.3 Start-up



DANGER

Electrical hazard!

It may be necessary to open the housing in order to perform work on the unit. Exposed parts may be energised and cause an electric shock if they are touched.

Observe the following points when working on the electrical system:



- Observe the "Safety" section.
 - Ensure that the tasks are performed solely by qualified experts.
1. Disconnect the unit from the power supply in order to deenergise it.
 2. Secure the unit so that it cannot be switched on again accidentally.
 3. Check whether the unit is properly disconnected from power and absolutely voltage-free
 4. Earth and short-circuit the unit.
 5. Cover any adjacent live parts and secure the danger area.

Prior to the start-up, the following tasks must be performed:

- Set the unit up.
- Connect the cooling water supply.
- Connect the power supply.
- Vent the unit.

► Note

The set-up, start-up, maintenance, and service should be performed by the after-sales service. If necessary, contact the after-sales service (see the "Contact addresses" section).

5.4 Installation

► Note

Comply with the instructions that are given in the "Safety/Selecting the installation site" section.

Comply with the maximum lengths (hoses, pipes, cables etc.) and pressure and temperature values as stated in the "Technical Data" section.

The connections to the unit must be flexible and sufficiently pressure- and temperature-proof.

5.5 Connections

! Notice

Risk of damage to components!

Closed shut-off devices in the chilling medium circuit lead to impermissible temperatures, thereby causing the unit to be switched off, or they can damage the unit.

Ensure that the shut-off devices inside the unit and on site are open prior to starting the unit.

Notes concerning the chilling medium connection

- The customer-provided chilling infrastructure (external water circuit) must be dimensioned by the system planner while taking into consideration the available pump pressure, pump design, nominal pipe widths, and the expected pressure losses in the consumer circuit (cooling modules).
- Keep the pipes (chilling medium) as short as possible in order to avoid pressure losses in the system.
- The chilling medium pipes can be either fixed or flexible. The compatibility of the materials in the cooling modules with the materials of the external system circuit must be taken into consideration in order to avoid damage due to corrosion.
- When installing the customer-provided pipes, contamination of the pipes must be absolutely avoided. Flush the pipes prior to connecting the cooling module.
- We recommend installing customer-provided shut-off and drain valves on every cabinet or cooling module as well as using a central water filter and air separator.

Connect the unit.

► Note

Connection sizes according to the "Technical Data" section

► **Note**

- Depending on the variant, the connectors and the condensate outlet are located at the top or bottom of the cooling module. The pipes are fed in/out through the bottom or top of the unit cabinet.
- Connectors that are not required must be sealed with blind plugs.

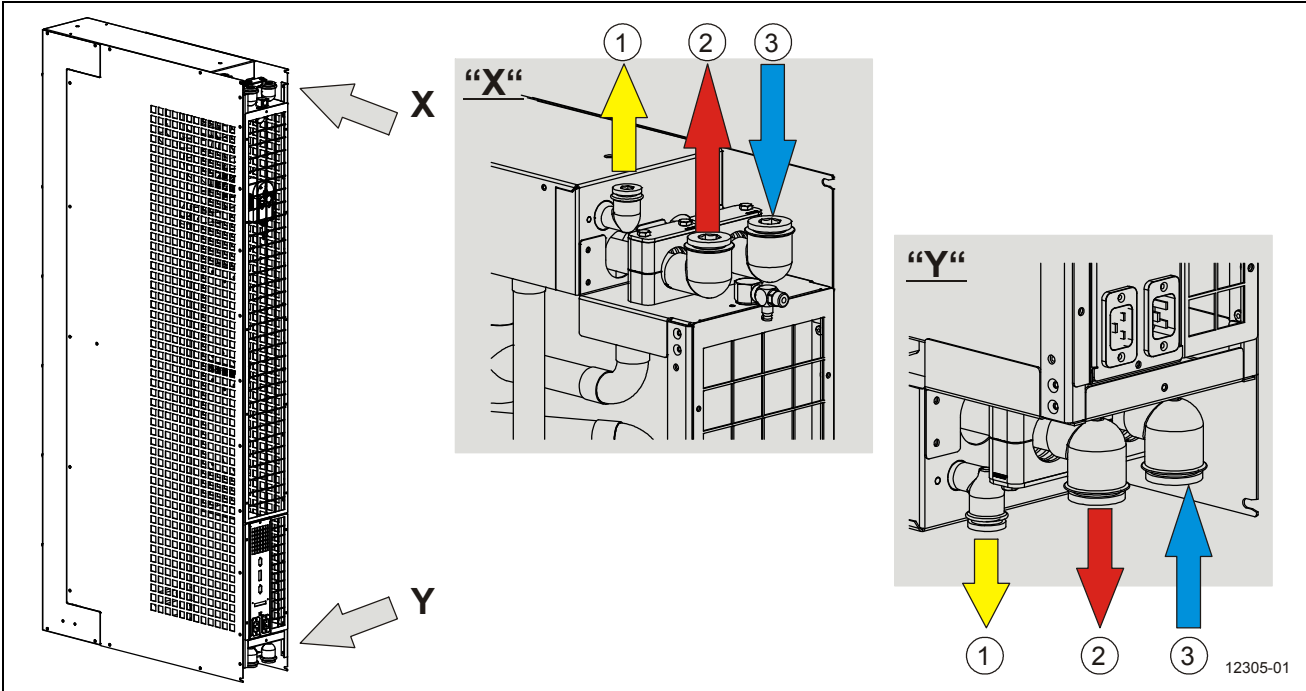

Fig. 14: Chilling medium connectors

X	Connectors (top)	1	Condensate outlet
Y	Connectors (bottom)	2	Chilling medium outlet
		3	Chilling medium inlet

- Connect the chilling medium inlet.
- Connect the chilling medium outlet.
- Connect the condensate outlet with a sufficient gradient to the wastewater system.

5.6 Electrical connection

**DANGER****Danger to life due to electrical hazard!**

There is a risk of death by electric shock if the connected voltages are not correct.

- Only qualified and specialised personnel is authorised to perform the connection.
- Compare the connection voltage to the voltage that is stated on the type plate.
- Comply with the specifications of the circuit diagram.

**DANGER****Electrical hazard!**

It may be necessary to open the housing in order to perform work on the unit. Exposed parts may be energised and cause an electric shock if they are touched.

Observe the following points when working on the electrical system:



- Observe the "Safety" section.
 - Ensure that the tasks are performed solely by qualified experts.
1. Disconnect the unit from the power supply in order to deenergise it.
 2. Secure the unit so that it cannot be switched on again accidentally.
 3. Check whether the unit is properly disconnected from power and absolutely voltage-free
 4. Earth and short-circuit the unit.
 5. Cover any adjacent live parts and secure the danger area.

! Notice**Wrong connected voltage!**

Incorrect supply voltages can lead to component damage.

Compare the supply voltage value with the voltage specification stated on the nameplate. Ensure the necessary fuse protection in accordance with the "Technical Data" section or circuit diagram.

► Note

- Units with two mains power inputs are designed for the redundant power supply via two independent mains power sources.
- The unit is supplied with operating voltage via an IEC320-C20 connector with cable lock at the back of the unit.
- A corresponding connecting cable (IEC320-C19 - two-pin earthed connector) is included in the scope of supply.
- The units must be protected by a series fuse in the building in accordance with the "Technical data" section.

► **Note**

Follow the instructions given in the circuit diagram.

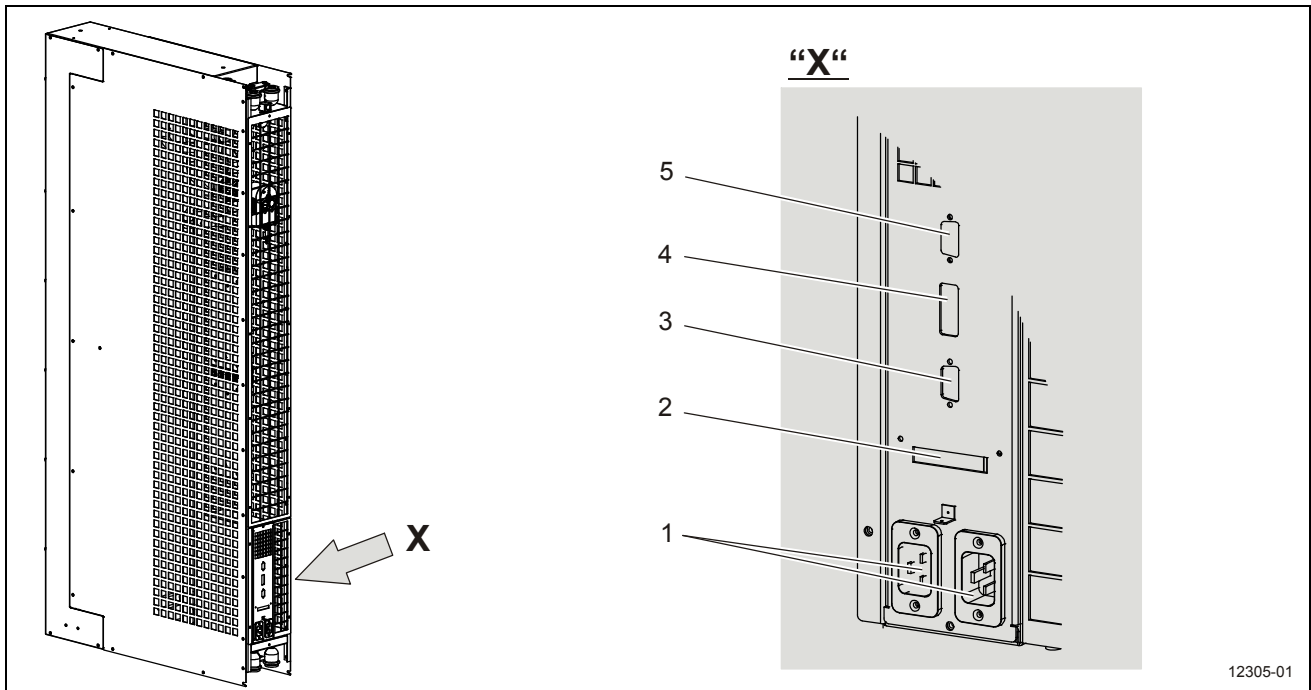

Fig. 15: Electrical connection

- If necessary, connect an interface cable for the device communication:
 - Interlocks (DI/DO), 10 pin (2)
 - RS232, 6 pin (3)
 - 2x RJ45 (4)
- Connect the external temperature sensor (5) (depending on the customer requirements).
- Connect the power supply (1).
- Observe the local rules and regulations.
- See the "Technical data" section.

► **Note**

- In order to avoid communication problems, lay the interface cable (data line) and the electrical power supply cables separate from each other.
- Once the operating voltage has been applied, the unit is in the standby mode. Various components inside the unit are live.
- Disconnect the operating power supply prior to opening the unit.
- Once the operating voltage has been applied, the actuator of the control valve is energised and performs an initialisation.

5.7 Antifreeze and anti-corrosion agents

If aluminium is used in the external water circuit, there is a risk of corrosion. In order to avoid electrochemical corrosion, it must be checked whether the materials that are used in the cooling module are compatible with the materials of the external cooling circuit.

The type and dose of a suitable anti-corrosion or anti-freeze agent depends on the situation on site and also on the external re-cooling system. It must be determined by the system planner.

The following materials are used in the cooling module.

- copper
- brass
- stainless steel
- gunmetal

In order to protect the components in the system circuit against corrosion and frost damage, the system circuit must be filled with an anti-corrosion and anti-freeze agent. Frost damage may be caused by contamination, air that is trapped inside the system, or by a pump malfunction.

! Notice

Damage to components

If the concentration of anti-corrosion or anti-freeze agents is too high or too low in the circuit, components may be damaged (e.g. the seals). If the concentration is too low, the corrosion may actually be stimulated.

When using anti-corrosion or antifreeze agents, please comply with the information provided by the manufacturers concerning the area of application, the compatibility with other materials, and the minimum/maximum mixing ratio, etc.

When using monoethylene glycol as the anti-corrosion and anti-freezing agent, please observe the following points:

- Do not mix anti-corrosion and anti-freezing agents of different manufacturers. Document the name and type of the anti-corrosion and anti-freezing agent that is used.
- For filling the system control circuit with anti-corrosion and anti-freezing agents, we recommend mixing the liquids in advance with the aid of a filling pump.

► Note

In order to ensure the trouble-free operation of the unit, the water quality requirements as stated in the "Technical data" section must be fulfilled.

5.8 Adjustments

► **Note**

- Please refer to the "Operation/Control Unit" section for information concerning the operation of the control unit (display and operating unit).
- If an error is indicated, press the ESC key. Following the pressing of the ESC key, the first parameter will be displayed.
- Select the various parameters by pressing the up or down key.
- Eliminate the malfunction (see the "Troubleshooting" section).

1. Switch the cooling module on via the control unit (see the start screen) (parameter "Chiller" = "ON").
2. Check the following parameters at the control unit and adjust them if necessary:

Parameter	Description	Screen
Temperature	Adjustment of the set temperature (air outlet).	Start screen (overview)
Sensor selection	Selection of the temperature sensor for the temperature control.	
Fan power	Adjustment of the set speed of the fans.	
Valve position	Indication of the current opening degree of the cooling valve in %.	

5.9 Venting

In order to vent the cooling system, the control valve **must** be closed.

► **Note**

If the control valve is open, chilling medium may flow from the return flow and into the heat exchanger. Venting is not possible in this case.

The control valve is opened or closed by the electronic control system by way of an electric actuator and based on the chilling medium demand.

When the cooling module is switched off by the control system, the actuator closes the control valve. This process takes approximately 2 minutes.

If the operating voltage is disconnected before the actuator has closed the control valve, the control valve must be closed manually.

! **Notice**

Risk of damage to components!

There is a risk of damage if the actuator is manipulated while it is connected to the operating voltage.

Do not adjust the actuator manually unless it is disconnected from the operating power supply.

Prerequisite for venting:

- The water installation is complete. The inflow to the cooling module is still closed.
- The electrical installation is complete.
- Specialised personnel with access to the water installation is present.

► **Note**

If the system comprises several cooling units, vent the systems one after the other in order to ensure sufficient pressure for pushing the air out.

Steps:

1. Switch the cooling module off at the control unit.
2. Wait for approximately 2 minutes. During this time, the control valve will close automatically.
3. Open the back of the cabinet.
4. Ensure that the control valve has been closed via the actuator.
5. Disconnect operating power supply.

► **Note**

If the operating voltage is disconnected before the actuator has closed the control valve, the control valve must be closed manually.

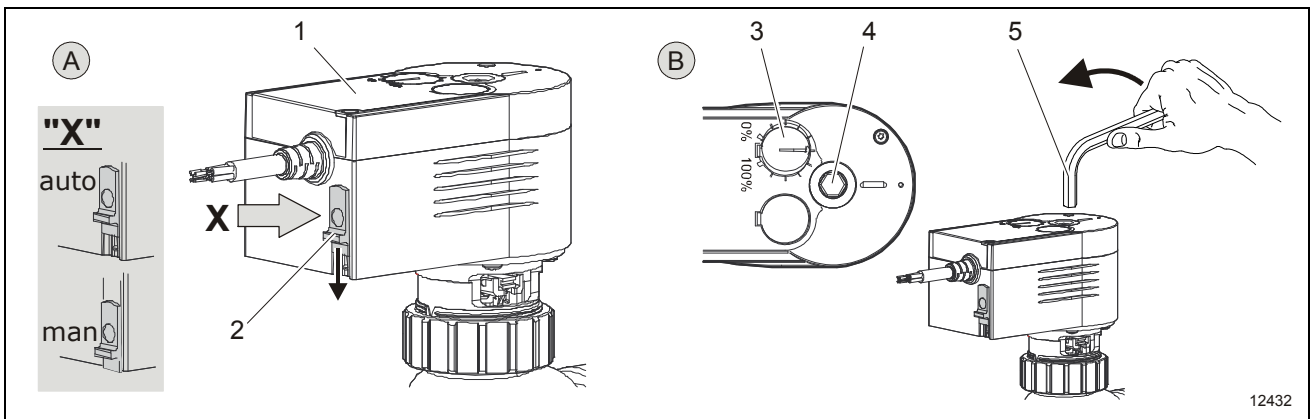

Fig. 16: Manually adjusting the actuator

6. If necessary, manually adjust control valve. Carry out the following steps:
 - Shift selector switch (2) of actuator (1) down to position "**Manual (man)**" (see "A").
 - Set adjusting screw (4) of actuator by way of using an Allen key (5) to an opening degree of the control valve of 0%.
Watch for display (3) (see "B").
 - Upon completion of works, shift selector switch (2) up to position "**Automatic (auto)**".

► **Note**

The power supply to the cooling module **must** be disconnected when the control valve needs to be adjusted manually.

7. Have the water inlet into the cabinets opened by specialised personnel. If present, open the shut-off valves upstream of the cabinets in the double bottom.
8. Insert the venting hose into a vessel with a capacity of 1.5 litres minimum.
9. Open the vent valve with the supplied square socket key and let the air escape. Close the vent valve when water starts to flow out.
10. Repeat these steps (starting with 7) for all of the cabinets.

Test run:

1. Connect the power supply.
2. Switch the cooling modules on via the operating unit.

► Note

The fans will briefly run with maximum speed. Then, they will be set back to their nominal speed. Since, at this point of time, there is no heat load in the cabinets, the set temperature (e.g. 20°C) will be reached rather quickly.

3. Open the vent valve once again briefly after the test run in order to check whether any air has collected in the heat exchanger.

The system is now completely filled with water and vented.

5.10 Removal/installation

 **WARNING****Risk of injury for personnel!**

There is an increased danger of injury during the installation or removal of the unit due to its size and weight.

Install or remove the unit always with several persons and with the aid of suitable lifting gear!

 **Note**

Prior to the removal, the cooling module must be disconnected from the water supply and the water connections must be closed in order to avoid damage caused by leaking cooling water.

1. Disconnect the electrical connections.
2. Disconnect the water connections.
3. Ensure that the water connections are closed prior to the removal.
4. Remove the front panel by unscrewing the fastening screws.
5. Loosen the fastening screws of the cooling module.
6. Pull the cooling module by its handle in the lower area out towards the front.

 **Note**

The installation is performed in reverse order.

 **Notice****Risk of damage to components due to improper installation or removal!**

Improper installation/removal of components will lead to the device being damaged. The correct functioning of the device will no longer be guaranteed.

- Have the components installed/removed only by specialised personnel.
- Contact the customer service department.

6 Operation

6.1 General information

! Notice

Danger of damage due to condensation!

At temperatures below 15°C/59°F, condensation may form inside the unit and cause damage to the unit when it is switched on.

Prior to switching the unit on, ensure that the unit has acclimatised sufficiently.

► Note

If the control system fails, the unit will switch to the emergency mode:

- maximum cooling power
- maximum fan power

6.2 Adjustments

► Note

- Please refer to the "Operation/Control Unit" section for information concerning the operation of the control unit (display and operating unit).
- If an error is indicated, press the ESC key. Following the pressing of the ESC key, the first parameter will be displayed.
- Select the various parameters by pressing the up or down key.
- Eliminate the malfunction (see the "Troubleshooting" section).

1. Switch the cooling module on via the control unit (see the start screen) (parameter "Chiller" = "ON").
2. Check the following parameters at the control unit (see the start screen) and adjust them if necessary:

Parameter	Description
Temperature	Adjustment of the set temperature (air outlet).
Valve position	Indication of the current opening degree of the cooling valve in %.

6.3 Switching off the unit

! Notice

Danger of damage due to condensation!

If the operating voltage supply of the cooling module is disconnected too early, the control valve will not fully shut. This may result in a generation of condensate and in damages of the unit or of the plant.

- After switching off the cooling mode at the control system, wait until control valve is fully closed.
- Note indication at control valve. The indicator shows 0%, if the control valve is closed.

1. Switch the cooling module off at the control unit.
2. Wait for approximately 2 minutes. During this time, the control valve will close automatically.
3. Ensure that the control valve has been closed via the actuator. The indicator at the control valve shows 0%.

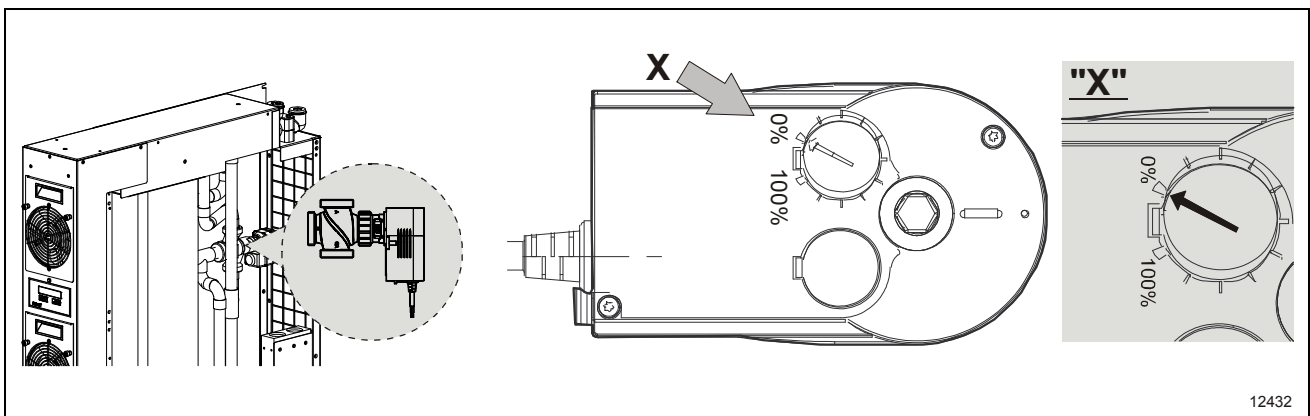

Fig. 17: Indicator at the control valve

4. Disconnect operating power supply.
5. Shut on-site locking valves in cooling agent supply.

6.4 Control unit

6.4.1 General information

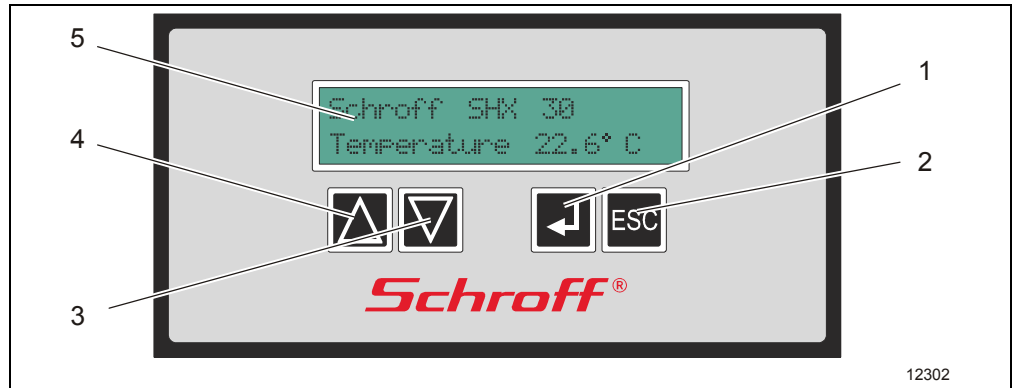





Fig. 18: Control unit (front view)

- 1 Confirmation key (Enter key)
- 2 Cancel key (ESC key)/backward key
- 3 Selection and setting key (down key)
- 4 Selection and setting key (up key)
- 5 Display

	<p>Selection and setting key (up key) Scrolling up through the lines of the menu. Following the selection of a parameter by way of the ENTER key, the parameter can be increased with the aid of this key. The value can be adopted by pressing the ENTER key again.</p>
	<p>Selection and setting key (down key) Scrolling down through the lines of the menu. Following the selection of a parameter by way of the ENTER key, the parameter can be decreased with the aid of this key. The value can be adopted by pressing the ENTER key again.</p>
	<p>Confirmation key (Enter key) Pressing the ENTER key adopts the selected parameter.</p>
	<p>Cancel key (ESC key)/backward key The current menu can be quit by pressing the ESCAPE key.</p>

6.4.2 Activating/deactivating functions

Proceed as follows in order to activate/deactivate the various functions:

1. Select the corresponding line by way of the up or down key. If several lines are displayed, the arrow indicates the selected line.
 - The current status (ON or OFF) is displayed at the end of the line.
2. Press Enter to change the current status.
 - The function will be activated or deactivated.
 - The new status (ON or OFF) will be indicated on the line on a black background.

6.4.3 Selecting and setting values

Notice

System configuration settings will affect the unit operation!

Unauthorised modification of the system configuration is prohibited since otherwise the correct operation of the unit can no longer be guaranteed.

The setpoints adjusted on delivery are default settings and may be changed only with permission from the after-sales service.

Parameters, setpoints, limits, and unit-specific data can be selected and adjusted using the selection and setting keys (up / down key).

Setting:

1. Select the desired line using the up or down key.
2. Press Enter.
3. Adjust the desired value using the up or down key.
4. Press Enter to save the setting.

Note

The setting procedure can be cancelled by pressing the ESC key.

6.4.4 Program overview

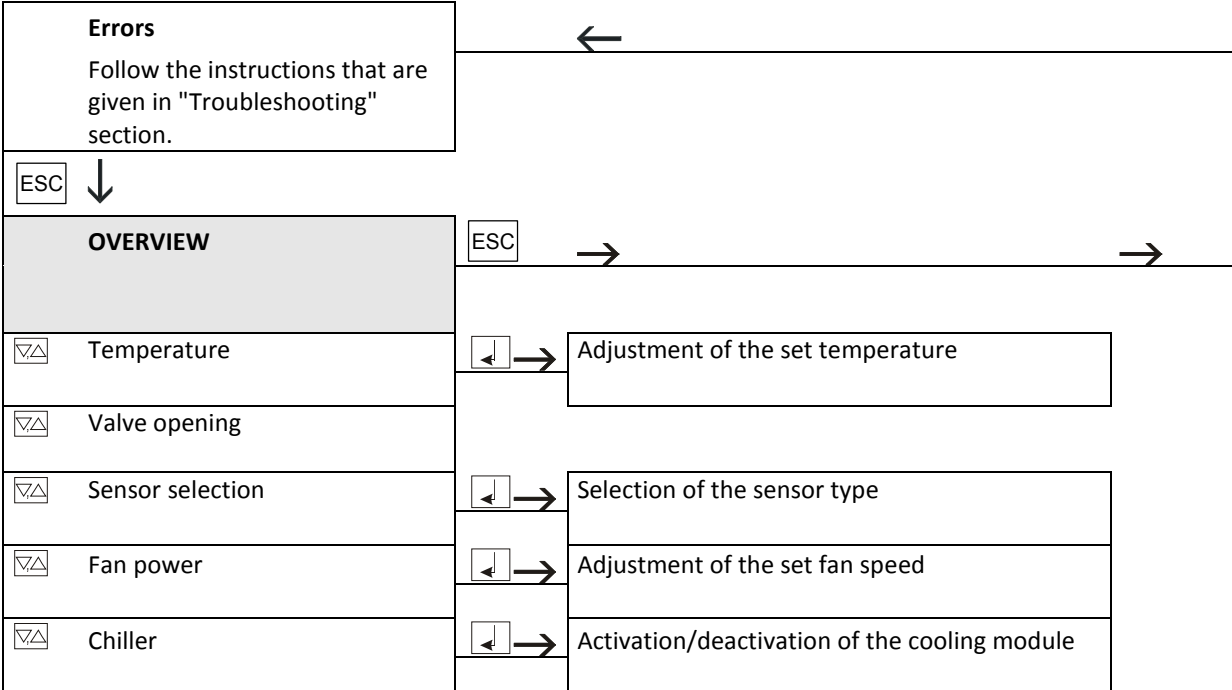

6.4.5 Screen contents and descriptions

► **Note**

Default values are indicated in brackets ().

Mask contents:	Description
OVERVIEW	This screen is also the start screen when the system is switched on. Display and modification of system-specific data.
Temperature	Indication of the actual temperature.
18-40°C (22°C) 64-104°F (71.6°F)	Adjustment of the default temperature. The limits of the setting range of the default values (MIN, MAX) can be adjusted in the mask "Configuration".
Valve opening	Indication of the opening degree of the cooling valve in per cent.
%	
Sensor selection	Selection of the temperature sensor for the determination of the actual temperature and for the temperature control.
=> top => average => bottom <= top <= average <= bottom External (=> average)	<= bottom: Temperature sensor in the air outlet, position in the lower cabinet area <= average: Determination of the actual temperature by averaging the temperatures of the upper/lower cabinet area <= top: Temperature sensor in the air outlet, position in the upper cabinet area => bottom: Temperature sensor in the air inlet, position in the lower cabinet area => average: Determination of the actual temperature by averaging the temperatures of the upper/lower cabinet area => top: Temperature sensor in the air inlet, position in the upper cabinet area External: External temperature sensor (option)
Fan power	Adjustment of the set fan speed.
30-100% (80%)	30%: minimum set fan speed 100%: maximum set fan speed
Chiller	Activation/deactivation of the cooling module
OFF/ON	ON: Cooling module switched on OFF: Cooling module switched off

7 Maintenance

7.1 General information



DANGER

Electrical hazard!

It may be necessary to open the housing in order to perform work on the unit. Exposed parts may be energised and cause an electric shock if they are touched.

Observe the following points when working on the electrical system:



- Observe the "Safety" section.
 - Ensure that the tasks are performed solely by qualified experts.
1. Disconnect the unit from the power supply in order to deenergise it.
 2. Secure the unit so that it cannot be switched on again accidentally.
 3. Check whether the unit is properly disconnected from power and absolutely voltage-free
 4. Earth and short-circuit the unit.
 5. Cover any adjacent live parts and secure the danger area.



WARNING

Danger of overturning!

Due to the slim set-up of the unit, there is a higher risk of injury when the unit tips over. Ensure that the unit is sufficiently secured during the transport.



WARNING

Danger to persons due to heavy objects!

When installing or removing components of the system (e.g., pumps, compressors, heat exchangers, ...), their entire weight must be taken into consideration.

- Perform the installation and removal with several persons or use suitable lifting devices.
- Install/remove the components individually one by one.
- Use personal protective equipment.

► **Note**

- Consumables (e.g. filters, batteries) must be disposed of in an environmentally sound manner and in accordance with the applicable national and local rules and regulations.
- Depending on the chemicals that are used (e.g. additives), the consumables must be disposed of as special waste in an environmentally sound manner and in accordance with the applicable national and local rules and regulations.
- For the disposal, please refer to the manufacturer-provided safety data sheets of the chemicals that are used.
- When disposing of the chemicals and consumables, wear suitable hand and eye protection as well as protective clothes.
- Comply with the information in the "Safety" section.

► **Note**

Do not use any detergents containing solvents.

7.2 Maintenance plan

Carry out the described maintenance tasks at the intervals specified in the maintenance schedule.

Maintenance intervals:

I	Daily	III	Monthly	V	Annually
II	Weekly	IV	Every six months		

Additional information:

E	Spare part required	K	Maintenance job to be carried out by the customer
----------	---------------------	----------	---

Component	Maintenance task	Equipment	E	I	II	III	IV	V	K
System / unit	Check for contamination and clean it.				X				X
	Check the pipe couplings and hose connections for leaks. If necessary, tighten the pipe couplings and hose connections or replace them.		X		X				X
Fan	Check for noise, replace if necessary.					X			X
Water circuit	Vent the system.					*)			X
	Check the concentration of the anti-freeze and anti-corrosion agents.							X	X
External chilling medium	Check the water quality.				X				X

*) following the opening of the water circuit

7.3 Replacement

7.3.1 Fans

► Note

A fan can be replaced while the system is in operation.

⚠ CAUTION

Danger of injury due to rotating fans!

During the installation/removal, there is a risk of injury due to the rotating fan.

Do not reach into the area of the rotating fan blades.

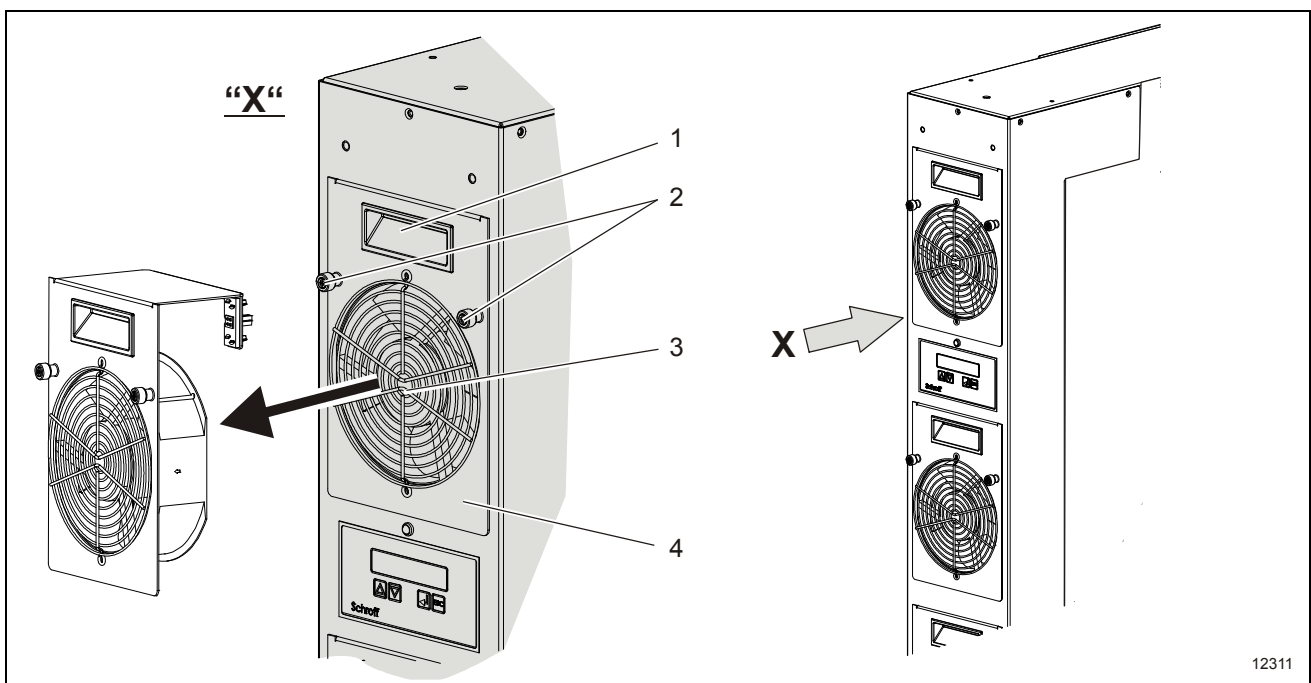

Fig. 19: Fan (example)

- | | | | |
|---|------------------|---|-------------------------------------|
| 1 | Recessed handle | 3 | Fan |
| 2 | Fastening screws | 4 | Front plate of the fan plug-in unit |

Remove the fan (3) as follows:

1. Unscrew the fastening screws (2).
2. Hold the fan (3) by its recessed handle (1) in the front plate of the plug-in unit (4) and pull it out of the cooling module.

► Note

The installation is performed in reverse order.

7.3.2 Actuator of the control valve

Notice

Damage to the actuator!

The actuator can be damaged as a result of improper handling.

Only qualified and specialised personnel is authorised to perform the installation and start-up.

1. Switch the cooling system off via the control unit.
2. Wait for approximately 2 minutes. During this time, the valve will close automatically.
3. Disconnect the cooling module from the operating voltage supply and secure it so that it cannot be reconnected.

Note

- The cooling module must be disconnected from the power supply in order to replace the electrical actuator.
 - Switching it off by way of the standby key does **not** disconnect the operating voltage. In this case, the actuator is still supplied with voltage. As a result, the actuator can be damaged when it is removed or installed.
4. Dismantle protection grid.

Notice

Damage to the temperature sensors!

The temperature sensors are fixed to the protective grid and may be damaged when removing the protective grid.

- Carefully remove protective grid.
 - If necessary, undo temperature sensors from protective grid.
5. Disconnect the plug of the actuator.

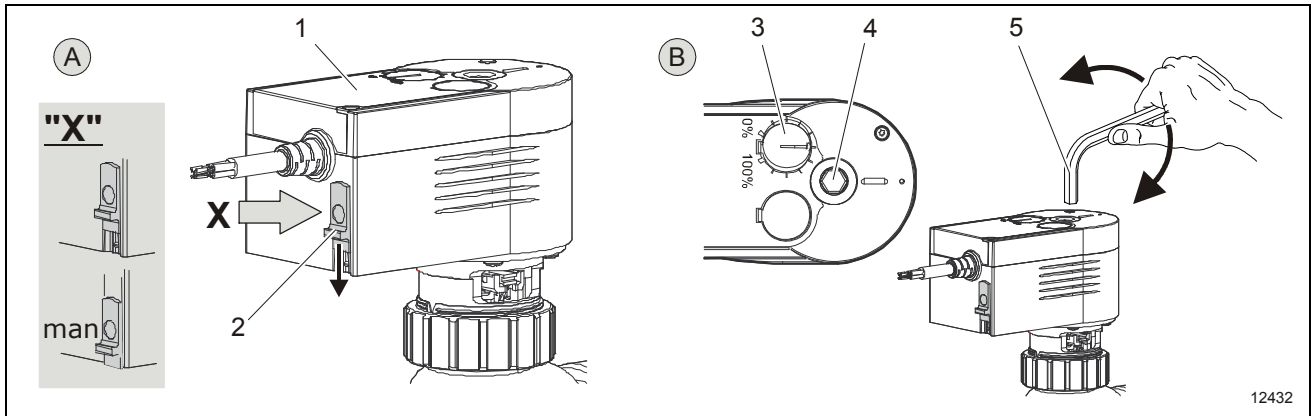

Fig. 20: Adjusting the actuator

See "A"

6. Shift selector switch (2) of actuator (1) down to position **"Manual (man)"** (see "A").

See "B"

7. Set adjusting screw (4) of actuator by way of using an Allen key (5) to an opening degree of the control valve of approx. 50%.
Note display (3).

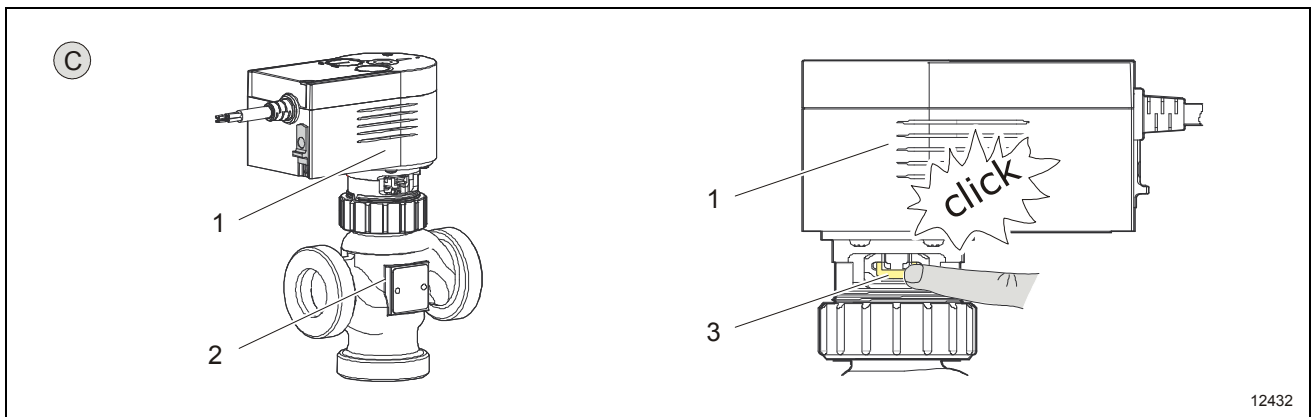

Fig. 21: Disconnect actuator

See "C"

8. Disconnect actuator (1) from control valve (2). For this purpose, push locking mechanism (3) at actuator (1). The unlocking is noticeable by a clicking noise.

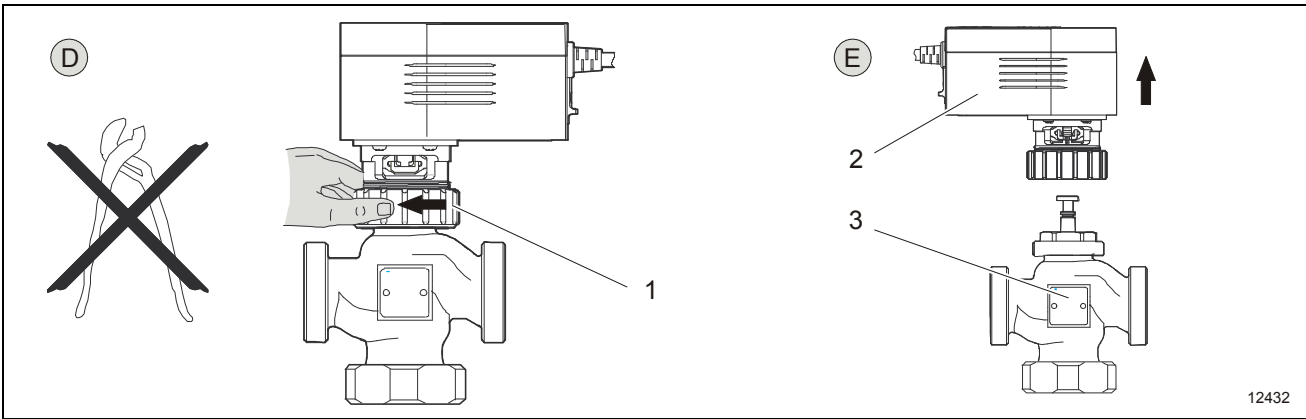

Fig. 22: Remove actuator to be replaced

See "D"

- 9. Loosen the union nut (1). See arrow.

Note

Do not loosen the union nut with a tool.

See "E"

- 10. Disconnect actuator to be replaced (2) from control valve (3).

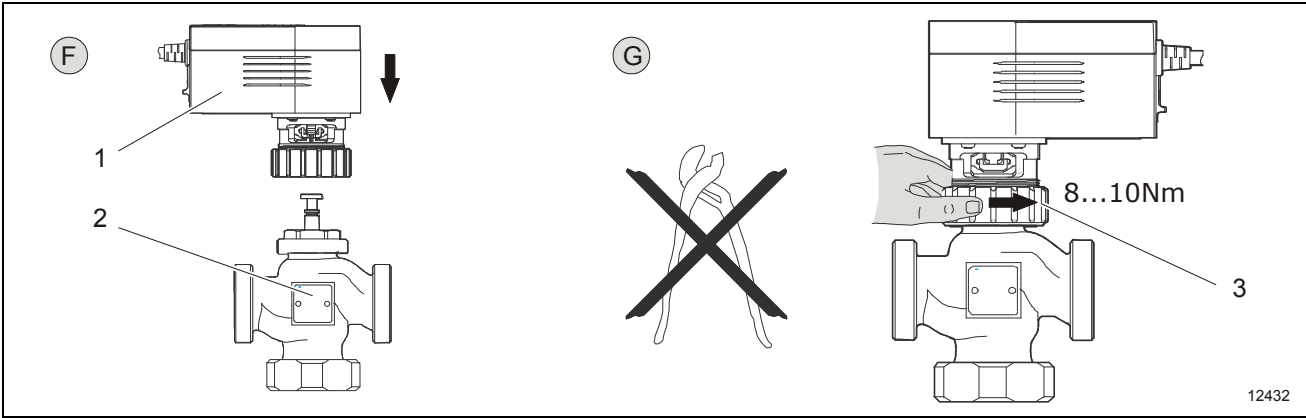

Fig. 23: Install the new actuator

See "F"

- 11. Plug new actuator (1) onto control valve (2).

See "G"

- 12. Tighten union nut (3) with a maximum torque of 8...10Nm. See arrow.

Note

Do not tighten the union nut with a tool.

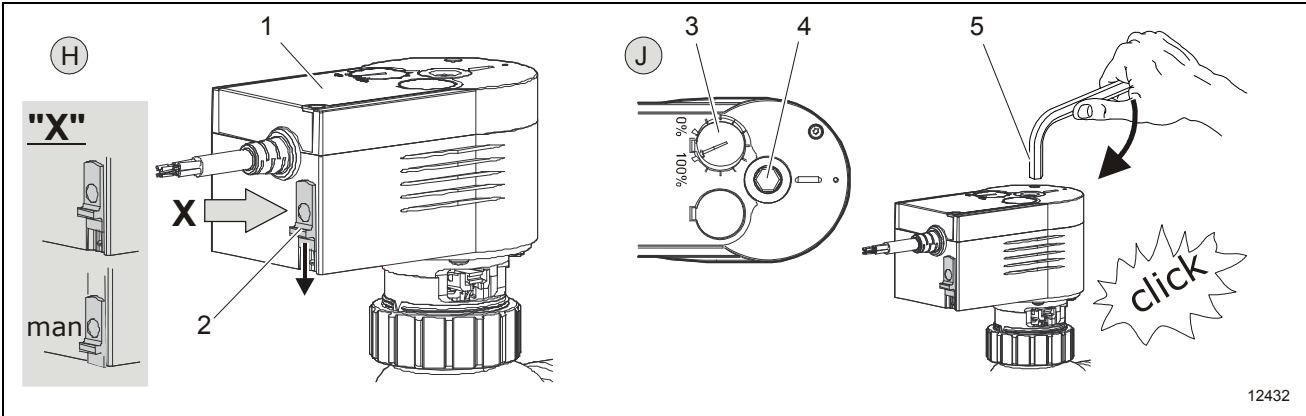

Fig. 24: Lock actuator, control valve

See "H"

- 13. Shift selector switch (2) of new actuator (1) down to position "Manual (man)".

See "J"

- 14. Turn adjusting screw (4) of actuator by way of using Allen key (5) in direction of 100%, until the lock is audibly engaged. Note display (3).

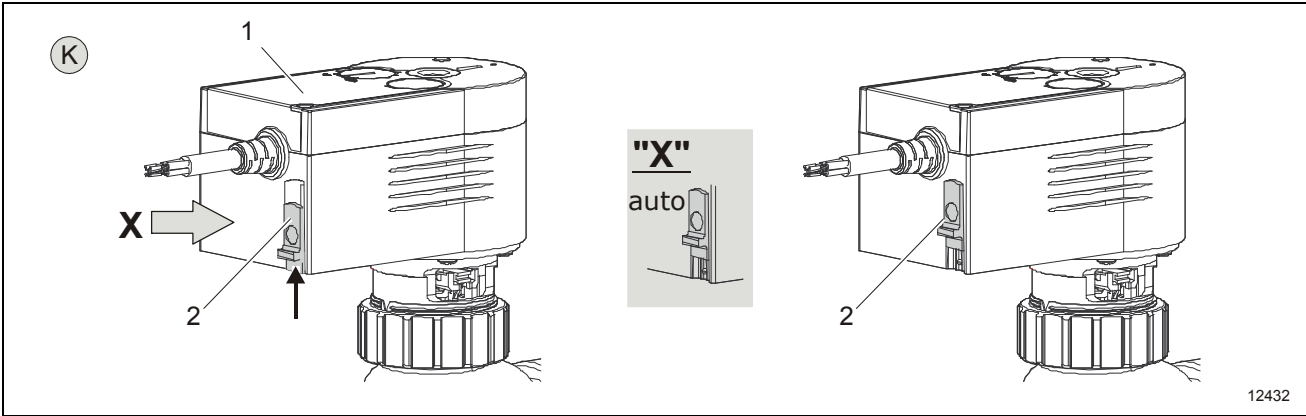

Fig. 25: Set selector switch

See "K"

- 15. Shift selector switch (2) of actuator (1) up to position "Automatic (auto)".

16. Install plug at actuator again.
17. Install protection grid.

! Notice

Damage to the temperature sensors!

The temperature sensors are fixed to the protective grid and may be damaged when installing the protective grid.

- Carefully install protective grid.
- If necessary, fix temperature sensors to protective grid again.

18. Connect cooling module to operating voltage.

▶ Note

After connecting operating voltage, an automatic initialization run of the control valve is carried out.

19. Switch on cooling at the unit control system again.

7.3.3 Temperature sensor

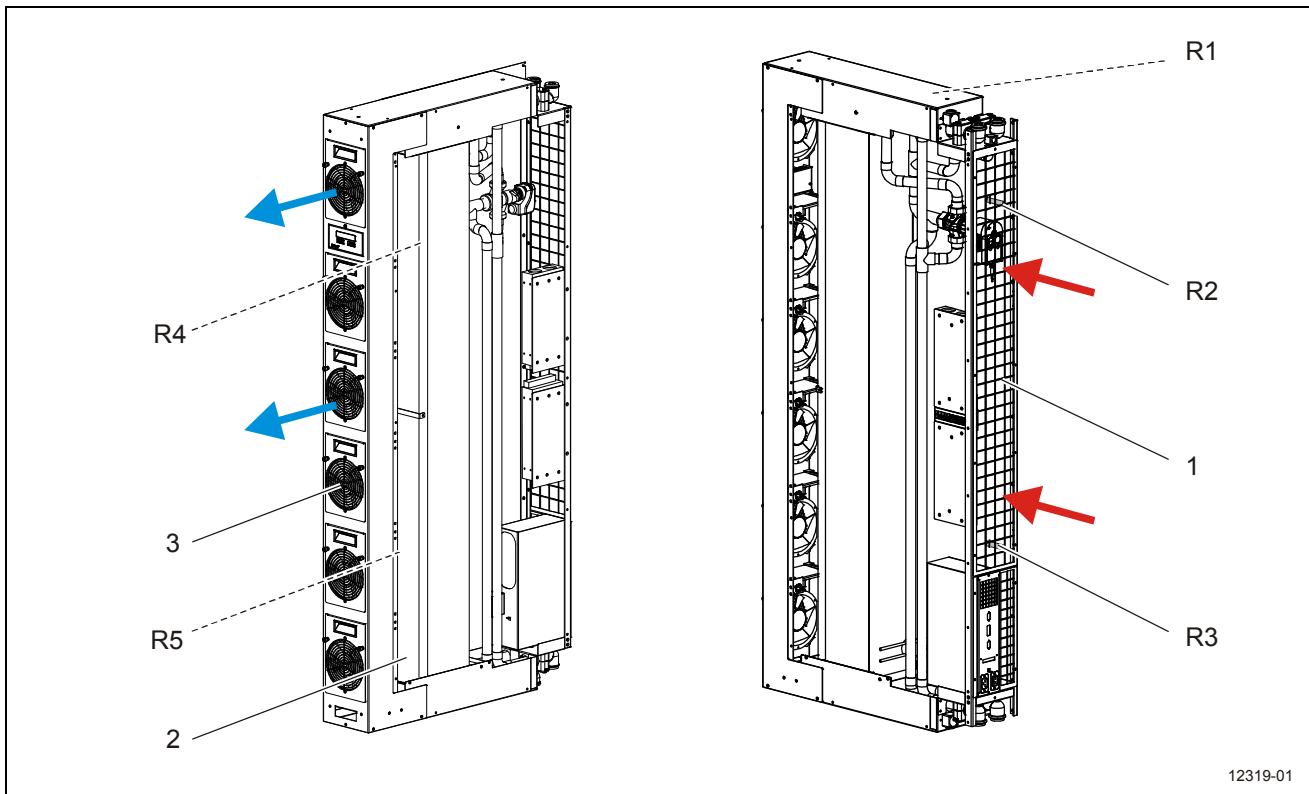

Fig. 26: Temperature sensor (example)

- The temperature sensor for measuring the water feed flow temperature (R1) is located in the pipe in the vicinity of the control valve.
- The temperature sensors for measuring the air intake temperature (R2, R3) are located at the back at the air inlet grid (1) and they are directly accessible.
- The temperature sensors for measuring the air outlet temperature (R4, R5) are located downstream of the demister (2). In order to remove the temperature sensors, the fans (3) must also be removed.
- The temperature sensors are connected to the basic electronic system (I/O unit) (see the electrical box).

► Note

- Refer to the circuit diagram.
- Refer to the "System Layout" and "Components" sections.

7.3.4 Replacement of other components

The replacement of other components on site is not intended. If the cooling module cannot be serviced by way of the measures that are described in this section, the entire cooling module must be removed and returned to Schroff.

7.4 Antifreeze and anti-corrosion agents



WARNING

Health hazard!

The use of chemicals can present a health hazard.

- Observe the safety data sheets.
- Wear protective clothing as stated in the safety data sheet when handling chemicals (e.g. safety goggles, face shield, respiratory equipment, safety gloves, safety shoes, etc.).

To ensure sufficient a concentration of the anti-freeze and corrosion protection agent, check the concentration according to the maintenance schedule.

This test is carried out using a conventional density measuring system or a refractometer. Observe the manufacturer' product information.

Check/top up an anti-freezing and anti-corrosion agent as follows:

1. Take a sample from the control circuit (e.g. at the filling and drain cock). Withdraw at least 0.5 l (0.1 gal) of the medium to achieve useful measuring results.
2. Measure the concentration with a suitable measuring device.
3. If the concentration is outside of the specified range, top up the anti-freezing and anti-corrosion agent.

► Note

- The chemicals that are required for the process are not included in the scope of supply.
- Please observe the safety data sheet of the chemicals that are used.

7.5 Cooling module

7.5.1 Rinsing process



WARNING

Health hazard!

The use of chemicals can present a health hazard.

- Observe the safety data sheets.
- Wear protective clothing as stated in the safety data sheet when handling chemicals (e.g. safety goggles, face shield, respiratory equipment, safety gloves, safety shoes, etc.).

When the cooling module is tilted and placed on its side, all of the water connections must be sealed since, otherwise, the medium that flows out can damage the electronic control system.

► Note

- The cooling module can be flushed with a commercially available, glycol-based anti-freeze agent (e.g. GLYSANTIN by BASF).
 - Ensure that the anti-freeze agent is compatible with the pipe system of the building.
 - Observe the safety data sheet.
1. Remove the cooling module.
 2. Seal the condensate outlet.
 3. Connect a pressure pump (hand pump) to the feed flow.
 4. Connect a hose (approx. 3 m) to the return flow.
 5. Open the actuator of the control valve by hand (see the procedure that is described in the "Start-up/Venting" section).
 6. Insert the suction hose of the pressure pump and the return flow hose of the cooling module into a vessel with a capacity of approximately 15 litres.
 7. Fill the vessel with approximately 3.5 litres of glycol (this ensures protection against freezing up to approximately -20°C).
 8. Switch the pump on and flush the cooling module for 5 to 15 minutes with glycol.
 9. Switch the pump off and open the vent valve of the heat exchanger.

► Note

If the pump has a non-return valve, the pump must be replaced with a hose.

10. If necessary, any other remaining water can be blown out of the heat exchanger by way of compressed air. To do so, connect the compressed air supply (max. pressure = 6 bar) to the feed flow.
Open the compressed air valve slowly in order to prevent the cooling water/glycol mixture in the collecting tank from overflowing.
11. After the draining process, seal the feed flow and return flow connections by way of suitable plugs.
12. Affix a sign with the following text (example) to the cooling module:

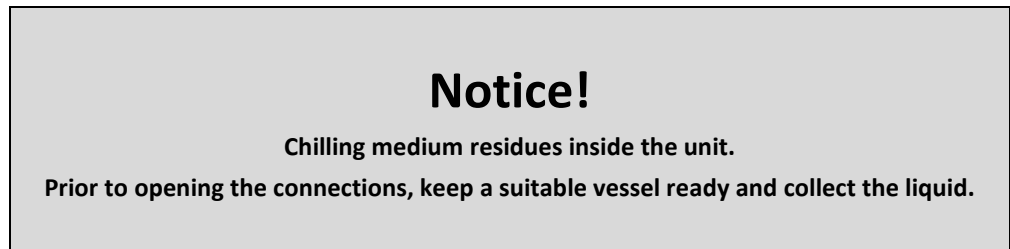

Fig. 27: Sign (example)

13. Dispose of the chilling medium in an environmentally-compliant manner and in accordance with the applicable local rules and regulations.

8 Troubleshooting

8.1 General information



WARNING

Carry out instructed works only!

There is an increased risk of injury to persons who perform tasks for which they are not suitably qualified or trained.

Troubleshooting shall only be carried out by qualified personnel. Contact the after-sales service particularly in the event of malfunctions in the electrical system or the refrigeration unit (if provided).



DANGER

Electrical hazard!

It may be necessary to open the housing in order to perform work on the unit. Exposed parts may be energised and cause an electric shock if they are touched.

Observe the following points when working on the electrical system:

- Observe the "Safety" section.
 - Ensure that the tasks are performed solely by qualified experts.
1. Disconnect the unit from the power supply in order to deenergise it.
 2. Secure the unit so that it cannot be switched on again accidentally.
 3. Check whether the unit is properly disconnected from power and absolutely voltage-free
 4. Earth and short-circuit the unit.
 5. Cover any adjacent live parts and secure the danger area.



WARNING

Danger to persons due to heavy objects!

When installing or removing components of the system (e.g., pumps, compressors, heat exchangers, ...), their entire weight must be taken into consideration.

- Perform the installation and removal with several persons or use suitable lifting devices.
- Install/remove the components individually one by one.
- Use personal protective equipment.

8.2 Electrical connection

Fault	Cause	Note
Unit not working.	No power supply.	Switch the power supply system on.
		Check the external fuse protection.
		Check the supply cable for signs of damage and ensure that it is properly connected.
		Check the electrical circuit.
		Check the fuses/micro-fuses.

8.3 Unit-specific

Fault	Cause	Note
Ambient temperature too high	Fan inoperative. The fuse on the fuse board has tripped.	Check and replace (see the "System Layout" and "Components" sections).
	Fan defective.	Check. Dismount and replace, if necessary.
	Incorrect setting of the parameters.	Contact the service department.

No or only insufficient medium flow	The control valve is defective.	Check and replace if necessary.
	The customer-provided shut-off valves are closed.	Check and open if necessary.
	The customer-provided feed pump is defective.	Check and replace if necessary.

The chilling medium is too warm.	The setting of the external cooling water supply is incorrect or the external cooling water supply is defective.	Check and adjust if necessary. Check the on-site components and replace them if necessary.
----------------------------------	--	---

The ambient temperature is too high.	The air cannot flow in/out.	Check the air inlets/outlets and keep them free.
--------------------------------------	-----------------------------	--

8.4 Control unit

► **Note**

- Malfunctions are indicated by a red, flashing LED above the control unit.
- Malfunctions are indicated on the display of the control unit.
- The errors/faults are displayed by way of a number.
- Select the corresponding error/fault with the up or down key.
- Acknowledge the errors/faults by way of the Enter key.

No.	Description	Cause	Note
2	Undervoltage 24 V	The supply voltage of the electronic control system is too low (below 14.5 V).	Check. Check the function of the power supply unit. Check the fuses and replace them if necessary. Acknowledge the error.
4 *)	Modbus communication	The RS485 interface has not received any telegrams for at least 10 seconds.	Check the interface cable (RJ45) for signs of damage and ensure that it is properly connected. Check the Modbus interface (interface address RS485 > 0). Contact the service department if necessary.
10 *)	Demo mode active	The demo mode has been selected.	Deselect the demo mode. Contact the service department.
11	Basic electronic system	No CAN communication between the control unit (display) and the remote I/O unit (basic electronic system).	Check the CAN address. Check the connecting cable between the control unit (display) and the remote I/O unit. Check the power supply. Acknowledge the error. Contact the service department if necessary.
12 *)	48V 1. Supply	Power supply unit no. 1 defective.	Check and replace if necessary. Check the fuses and replace them if necessary.
13 *)	48V 2. Supply	Power supply unit no. 2 defective.	Check and replace if necessary. Check the fuses and replace them if necessary.
15 *)	Cooling water temperature	Cooling water temperature too high.	Check and adjust if necessary.
		<ul style="list-style-type: none"> • The customer-provided filters are blocked. 	Clean and replace if necessary.
		<ul style="list-style-type: none"> • The customer-provided shut-off valves are closed. 	Open.
		<ul style="list-style-type: none"> • Control valve defective. 	Check the power supply. Replace the control valve if necessary. Contact the service department if necessary.
		<ul style="list-style-type: none"> • Failure of the control system. 	Check and replace if necessary. Contact the service department if necessary.

*) After the elimination of the error/fault, the error will be automatically reset.

No.	Description	Cause	Note
16 *)	Temperature error	See the section "Unit-specific".	See the section "Unit-specific".
17 *)	MAX cooling active	The actual temperature is higher than the default temperature including the adjustable temperature difference. Due to excessive air temperatures, the chiller runs with a completely open control valve and maximum fan power.	Check. Check the parameters at the control unit and adjust them if necessary. Contact the service department.
		See the section "Unit-specific".	See the section "Unit-specific".
18	Condensate pump	The float switch or condensate pump are defective.	Check and replace if necessary.
		The drain hose is blocked.	Check and unblock if necessary.
			Acknowledge the error.
19 *)	MAX cooling manual	The chiller runs with maximum cooling power and maximum fan power. The parameter " MAX cooling " is activated at the control unit.	Deactivate the parameter "MAX cooling" at the control unit. Contact the service department.
21-27 *)	Fan 1-6 (7)	Fan defective.	Check and replace if necessary.
		The fuse on the fuse board has tripped.	Check and replace if necessary.
		The plug-in unit is not connected properly.	Check and connect the plug-in unit properly if necessary.
28	Door open	No external release signal. The door is open.	Close the door and acknowledge the error.
31	Cooling water temperature sensor	The temperature sensor is defective (e.g. cable break).	Check and replace if necessary. Acknowledge the error.
32	Temperature sensor => top		
33	Temperature sensor => bottom		
34	Temperature sensor <= top		
35	Temperature sensor <= bottom		
36	External temperature sensor (option)		

*) After the elimination of the error/fault, the error will be automatically reset.

9 Disconnecting the device

9.1 General information

WARNING

Risk of injuries for persons due to heavy objects!

The components mentioned above are very heavy and bulky.

Always have several persons carry out the installation or dismantling or use appropriate lifting devices!

WARNING

Connections alive!

Carelessness can lead to electrocution.

Disconnect the electricity supply before disconnecting the unit.

9.2 Dismantling

WARNING

Incorrect shut-down!

Pressurised systems (if installed) can present an increased danger source.

Depressurise all of the circuits prior to dismantling the system or unit.

The following steps must be performed:

1. Remove all of the electrical connections leading to the system or unit.
2. Disconnect the medium connections (e.g. water connections).
3. Remove all of the hose connections leading to the system or unit.
4. Depressurise the circuit. If necessary, tilt the unit in order to empty it completely.

9.3 Transport and storage

Notice

Danger of frost

Damage caused by freezing cooling water in the device.

Completely drain the device before transportation.

Note

Transport the unit carefully and in a shock-free and vibration-free manner.

Please note the following:

- The unit must be completely drained before transport.
- The unit must be completely drained before storage.
- The unit must be transported in a vertical position. Do not throw it.
- The unit must be stored in a vertical position.
- Ensure that the ambient conditions are in line with the "Technical data".
- Use suitable packaging material (e.g. shock-absorbing and vibration-absorbing).
- Ensure that the packaging will protect the unit against dust and dirt.
- Pack the unit so that it is protected against shocks and falling down.
- Ship the unit on a pallet only with belts wrapped around.
- If the unit is shipped separately, use the original padding blocks and mark as follows:
 - "Protect against moisture"
 - "Transport and store in upright position"
 - "Fragile"

9.4 Recycling



WARNING

Improper disposal!

Improper disposal of the media and components used has a negative environmental impact. All media have to be disposed of in accordance with the information provided by the manufacturer and with national and local regulations.

The components of the unit are basically made of the following materials:

- plastic
- non-ferrous metals
- stainless steel
- steel and aluminium components
- electronic modules

10 Technical Data

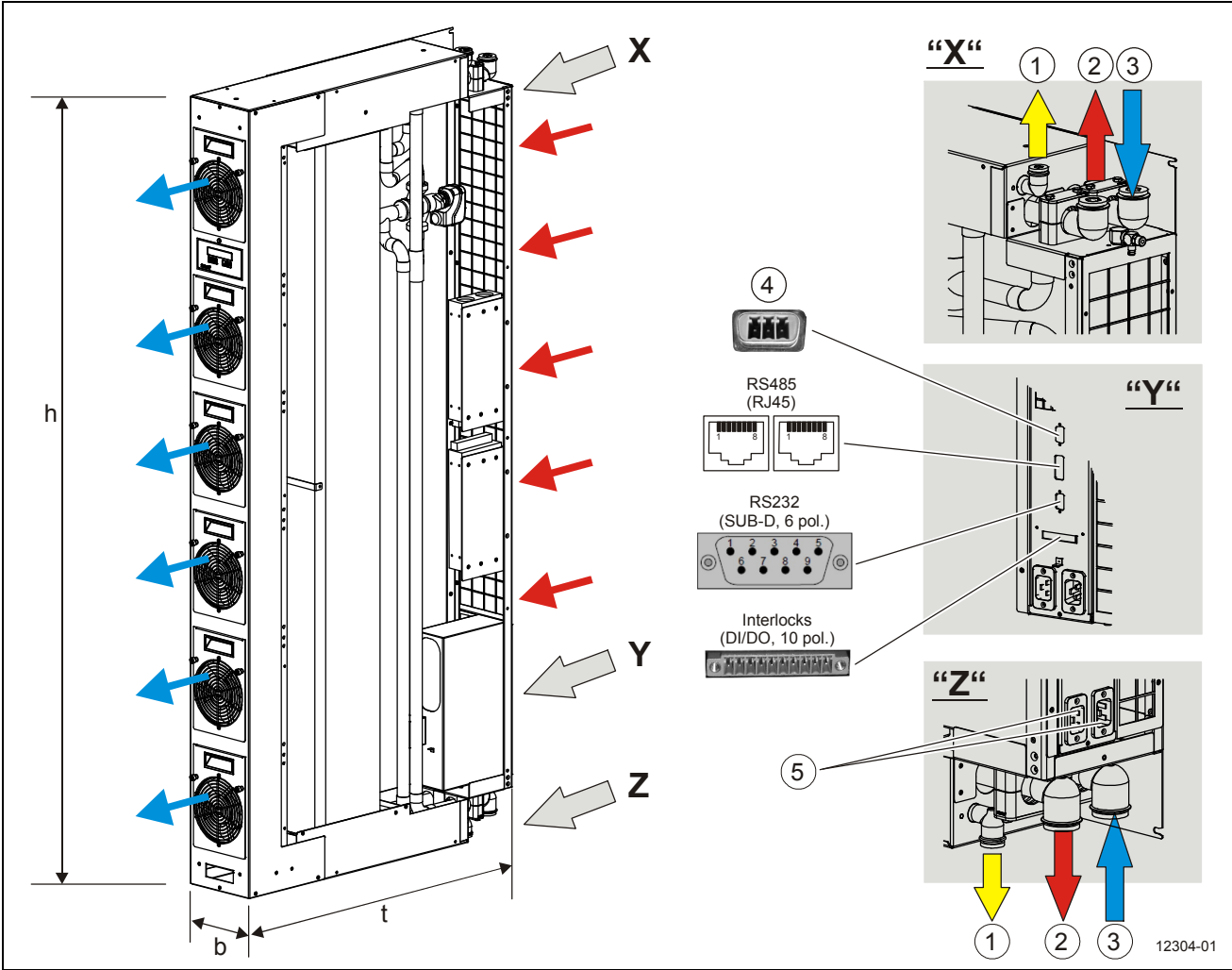

Fig. 28: Cooling module

- 1 Condensate outlet
- 2 Chilling medium outlet
- 3 Chilling medium inlet
- 4 External temperature sensor (option)
- 5 Electrical power connection point

- Detail view**
- X Connectors (top)
 - Y Data interface
 - Z Connectors (bottom)

- Interfaces**
- Data interface (RS485, 2x RJ45)
 - Data interface (RS232, SUB-D, 6 pin)
 - Interlock-interface (DI/DO, 10 pin)

Dimensions			
Cooling unit	Width	mm	300
	Depth	mm	1000-1200
	Height	mm	2100 / 2300
	Protection class	IP	55
Cooling module	Width	mm	189,5
	Depth	mm	850
	Height	mm	1849

VARISTAR Cooling unit SHX 30

General data			
Ambient conditions	Temperature for transport and storage when completely empty or flushed with 35% glycol	°C	-25 ... +70
	Relative humidity for transport and storage (non-condensing)	%	5 - 95
	Temperature outside of the cabinet during the operation (min./max.)	°C	5 - 70
Sound pressure level	at 80% fan speed	dB (A)	79
	at 100% fan speed	dB (A)	84
Weight	Cooling module	kg	110
	Cooling unit (cooling module and cabinet)	kg	370

Technical specification			
Nominal cooling power	max.	kW	30
Chilling medium		-	Water, water-glycol-mixture (33% max.)
Water circulation rate	max.	m ³ /h	4,3
Pressure loss inside the unit	measured at 3 m ³ /h	bar	1,3
	measured at 4.3 m ³ /h	bar	3,0
Water inlet temperature	min./max.	°C	6 / 18
Volumetric air flow	max.	m ³ /h	5000
Control temperature	adjustable (in steps of 0.1)	°C	18 - 50
Max. control deviation	adjustable emergency cooling of 0-8 K to the set value	K	4 (factory-set)

Electrical data (AC version)			
Supply voltage		V	100-240 / 1 / N / PE
		Hz	50/60
Max. current consumption	at 230V	A	6
	at 115V	A	12
Max. power consumption	fan speed 100%	W	1000
Power consumption during normal operation	fan speed 80%	W	750
Series fuse (building)	at 230V	A	D 10
	at 115V	A	D 16

Water pipe (copper)		
Water inlet/outlet connection	Rp	1"
Condensate drain connection	Rp	½"

Water quality			
Conductivity	at 25°C	mS/m	25 - 220
Hydrogen concentrate	(pH value) at 20°C	pH	7,5 - 8,5
Chloride		g/m ³	< 200
Water hardness		°dH	6 - 14
Colony forming units		KBE/ml	< 10.000
Appearance		-	clear, without sediment
Colour		-	colourless

► **Note**

In order to ensure the trouble-free operation of the cooling module, the water quality requirements must be fulfilled (see also VDI 3803).

11 Spare Parts

► Note

Only use genuine spare parts and filters, otherwise loss of warranty.

	Part no.	Description	
1	60130-720	Drive for the control valve	
2	60130-725	Fan plug-in unit incl. fan (assembly unit)	
3	60130-728	Connection cable	Schuko C19
4	60130-731	Connection cable Varistar SHX30 to EMX	3m
5	60130-732	Modbus end resistor (RS485)	270 Ohm

A		O	
Activating/deactivating.....	48	Operating faults	64
Actuator of the control valve.....	55	Operating personnel	7
Air circuit.....	14	Operation	45
Alarms	16	Overview	18
Anticorrosion agent	39, 61	P	
Antifreeze agent	39, 61	Packing material.....	34
B		Program overview.....	49
Basic electronic system.....	31	R	
C		Recycling	70
Components	26	Removal	44
Connections	20, 35	Replacement	54
Control method	15	Replacement of other components.....	60
Control unit.....	27, 47, 66	Replacement of the fans.....	54
Control valve.....	26	Rinsing process.....	62
Cooling module.....	62	S	
D		Safety	5
Description.....	12	Schematic system diagram	23
Disclaimer	11	Screen contents	50
Disconnecting the device.....	68	Selecting and setting values.....	48
Dismantling	68	Setting Up	32
E		Set-Up	10
Electrical box.....	22	Spare Parts.....	74
Electrical connection.....	37, 65	Start-up	34
F		Storage	69
Function overview	24	Switching off the unit.....	46
Fuse board	30	Symbols / labels on the unit.....	25
G		System Layout.....	18
General information regarding safety	5	T	
I		Technical Data.....	71
Incorrect use	16	Temperature sensor.....	60
Installation	35, 44	Transport.....	9, 69
Installation site	9	Transport material	34
Intended use	8	Type plates.....	8
Interface board	28	U	
M		Unit-specific	65
Maintenance.....	11, 51	V	
Maintenance schedule	53	Variants	12
Mode of operation.....	13	Venting.....	41

VARISTAR Cooling unit SHX 30

W

Warning notices..... 6

Warranty..... 8

Water circuit 14