

L-934SGD-5V

SUPER BRIGHT GREEN

### Features

- LOW POWER CONSUMPTION.
- GENERAL PURPOSE LEADS.
- RELIABLE AND RUGGED.
- LONG LIFE - SOLID STATE RELIABILITY.
- AVAILABLE ON TAPE AND REEL.
- 5V INTERNAL RESISTOR.

### Description

The Super Bright Green source color devices are made with Gallium Phosphide Green Light Emitting Diode.

### Package Dimensions

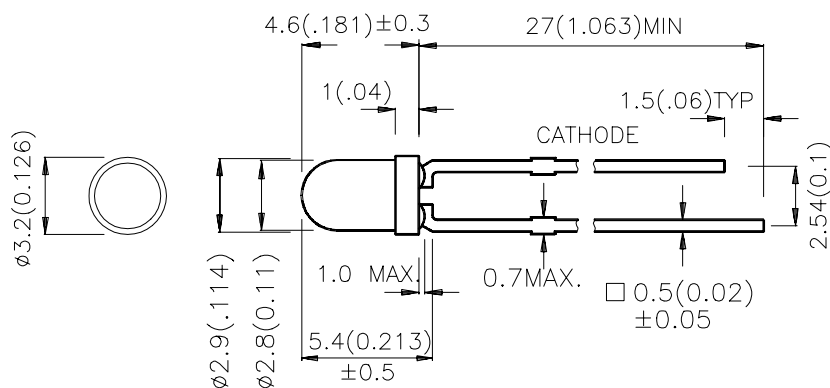

#### Notes:

1. All dimensions are in millimeters (inches).
2. Tolerance is ±0.25(0.01") unless otherwise noted.
3. Lead spacing is measured where the lead emerge package.
4. Specifications are subject to change without notice.

## Selection Guide

Part No.	Dice	Lens Type	Iv (mcd) V=5V		Viewing Angle
			Min.	Typ.	2θ1/2
L-934SGD-5V	SUPER BRIGHT GREEN (GaP)	GREEN DIFFUSED	8	20	60°

Note:

1. θ1/2 is the angle from optical centerline where the luminous intensity is 1/2 the optical centerline value.

## Electrical / Optical Characteristics at T<sub>A</sub>=25°C

Symbol	Parameter	Device	Typ.	Max.	Units	Test Conditions
λ <sub>peak</sub>	Peak Wavelength	Super Bright Green	565		nm	V <sub>F</sub> =5V
λ <sub>D</sub>	Dominate Wavelength	Super Bright Green	568		nm	V <sub>F</sub> =5V
Δλ <sub>1/2</sub>	Spectral Line Half-width	Super Bright Green	30		nm	V <sub>F</sub> =5V
I <sub>F</sub>	Forward Current	Super Bright Green	11.5	17.5	mA	V <sub>F</sub> =5V
I <sub>R</sub>	Reverse Current	Super Bright Green		10	uA	V <sub>R</sub> = 5V

## Absolute Maximum Ratings at T<sub>A</sub>=25°C

Parameter	Super Bright Green	Units
Power dissipation	85	mW
Forward Voltage	6	V
Reverse Voltage	5	V
Operating Temperature	-40°C To +70°C	
Storage Temperature	-40°C To +85°C	
Lead Solder Temperature[1]	260°C For 5 Seconds	

Note:

1. 2mm below package base.

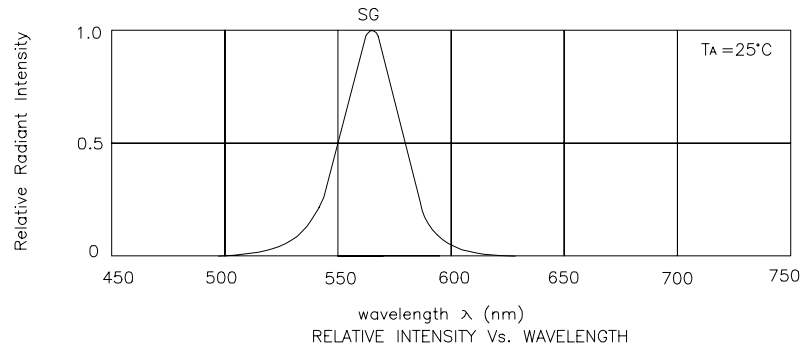

## Super Bright Green L-934SGD-5V

