



佛山市国星光电股份有限公司

FOSHAN NATIONSTAR OPTOELECTRONICS CO., LTD

# 产品规格书 SPECIFICATION

顾客名称 Customer		产品名称 Product	大功率 LED Power LED
顾客部品号 Customer No.		产品型号 Type	FP-6070CW-AFZ-ED1M

顾客确认 APPROVED SIGNATURES			



地址：广东省佛山市禅城区华宝南路 18 号

Add: NO.18 South Huabao Rd, Foshan, Guangdong, China

电话 (Tel): 086-0757-83985604, 83985605, 83985607

传真 (Fax): 086-0757-82100221, 82100223

邮编 (Zip): 528000

<http://www.nationstar.com>

研究开发中心 Research & Development Center		
批准 APPROVE	审核 CHECK	制定 DRAW
版本号 (Version No.): B		
文件发放日期 (Release Date): 2012-06-08		

# FP-6070CW-AFZ-ED1M

## 功率发光二极管 Power Light Emitting Diode

### 技术数据表 Technical Data Sheet

本产品在小尺寸上集成了高光强、高光效，长寿命等优点，其主要应用于为家庭日常照明，建筑照明，泛光照明，路灯以及各类商业和娱乐的装饰照明。例如：MR16, AR111, PAR, 球泡灯等。

This product combines high luminous, high illuminant efficiency and long working life with small package, it is generally used for common illuminate, architectural lighting, street lighting or commercial and entertainment decorative lighting. Such as MR16, AR111, PAR, and light bulb replacements.

#### 特性:

##### Features:

- 白色大功率 LED  
White Power LED
- 功率等级: 1W  
Power: 1 W
- 视角宽: 120°  
Wide View Angle: 120°
- 热阻低: 7 K/W  
Low Thermal Resistance: 7 K/W
- 高亮度, 高发光效率  
High Luminance, high illuminant Efficiency
- 体积小, 可靠性高  
Small Package and Good Reliability
- 符合欧盟公布 RoHS 指令  
Complied With RoHS Directive

## 目录

### Catalogue

外形尺寸 Outline Dimensions .....	2
参数 Characteristics.....	3
分档标准 Ranking Criteria.....	4
典型特性曲线 Typical Characteristic Curves .....	6
可靠性实验 Reliability Test Items And Conditions.....	7
包装 Packaging.....	8
焊接指导 Guideline for Soldering.....	10
使用注意事项 Precautions.....	12

# 外形尺寸

## Outline Dimension

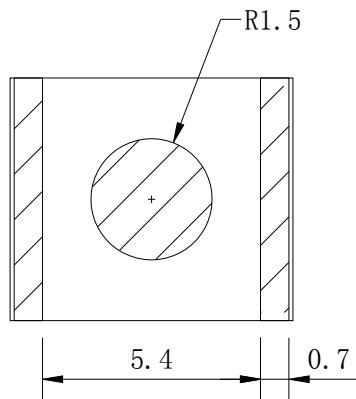
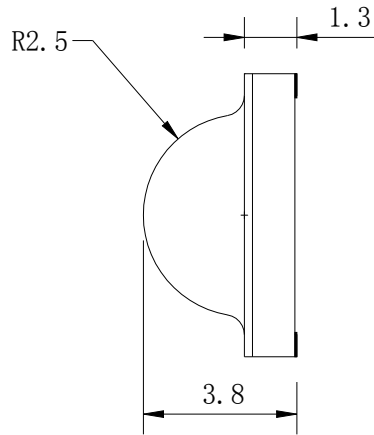
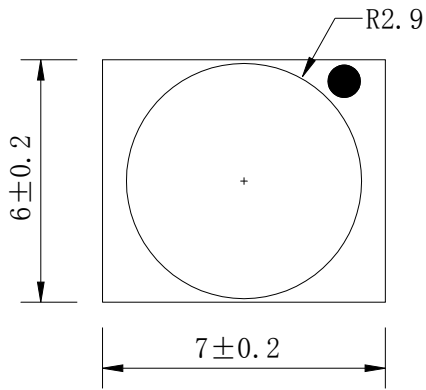

### ◇ Solder Land 焊盘尺寸图:

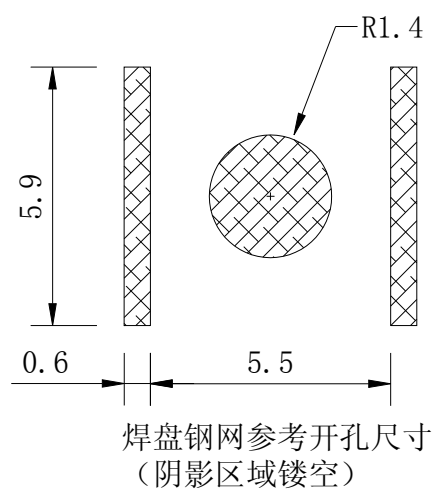
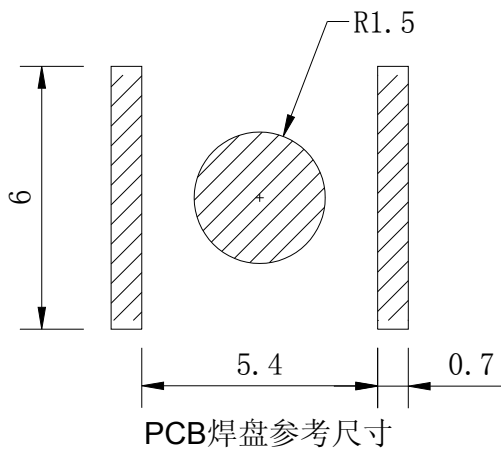

单位: mm, 未注公差:  $\pm 0.1$  mm

All dimensions in mm, tolerances unless mentioned is  $\pm 0.1$  mm.

## 参数

### Characteristics

- ◇ **极限参数 (温度=25°C):**  
**Absolute Maximum Ratings (Temperature=25°C):**

参数名称 Parameter	条件 Condition	符号 Symbol	数值 Rating	单位 Unit
正向电流 Forward Current	Ta=25°C, Tj<120°C	I <sub>F</sub>	500	mA
反向电压 Reverse Voltage	Ta=25°C	V <sub>R</sub>	5	V
功耗 Power Dissipation	Ta=25°C	P <sub>D</sub>	2	W
正向脉冲电流* Pulse Forward Current*	Ta=25°C 1/10 duty cycle @ 1 KHZ	I <sub>FP</sub>	700	mA
工作温度范围 Operating Temperature	LED 结温 Junction	T <sub>j</sub>	120	°C
	环境温度 Ambient	T <sub>a</sub>	-20 ~ +85	°C
贮藏温度 storage Temperature	-	T <sub>stg</sub>	-30 ~ 100	°C

\* Ta : 表示环境温度; Tj : 表示 LED 结温;

\* 注: 脉冲宽度≤0.1ms, 占空比≤1/10

\* Note: Pulse width≤0.1ms, Duty≤1/10

- ◇ **光电参数 (温度=25°C):**  
**Electro-Optical Characteristics (Temperature=25°C):**

参数名称 Parameter	符号 Symbol	条件 Condition	最小值 Min.	典型值 Typ.	最大值 Max.	单位 Unit
正向电压 Forward Voltage	V <sub>F</sub>	I <sub>F</sub> =350mA	3.0	3.3	3.6	V
反向电流 Reverse Current	I <sub>R</sub>	V <sub>R</sub> =5V			10	μA
色温 Color temperature	T <sub>c</sub>			6000		K
显色指数 CRI	R <sub>a</sub>			70		
光通量 Flux	Φ <sub>v</sub>	I <sub>F</sub> =350mA	110	120		lm
发光角度 View Angle	2θ <sub>1/2</sub>			120		deg.
热阻 Thermal Resistance	R <sub>θ</sub>			7		K/W

# 分档标准

## Ranking Criteria

色坐标分档图  
Chromaticity Diagram of Ranking

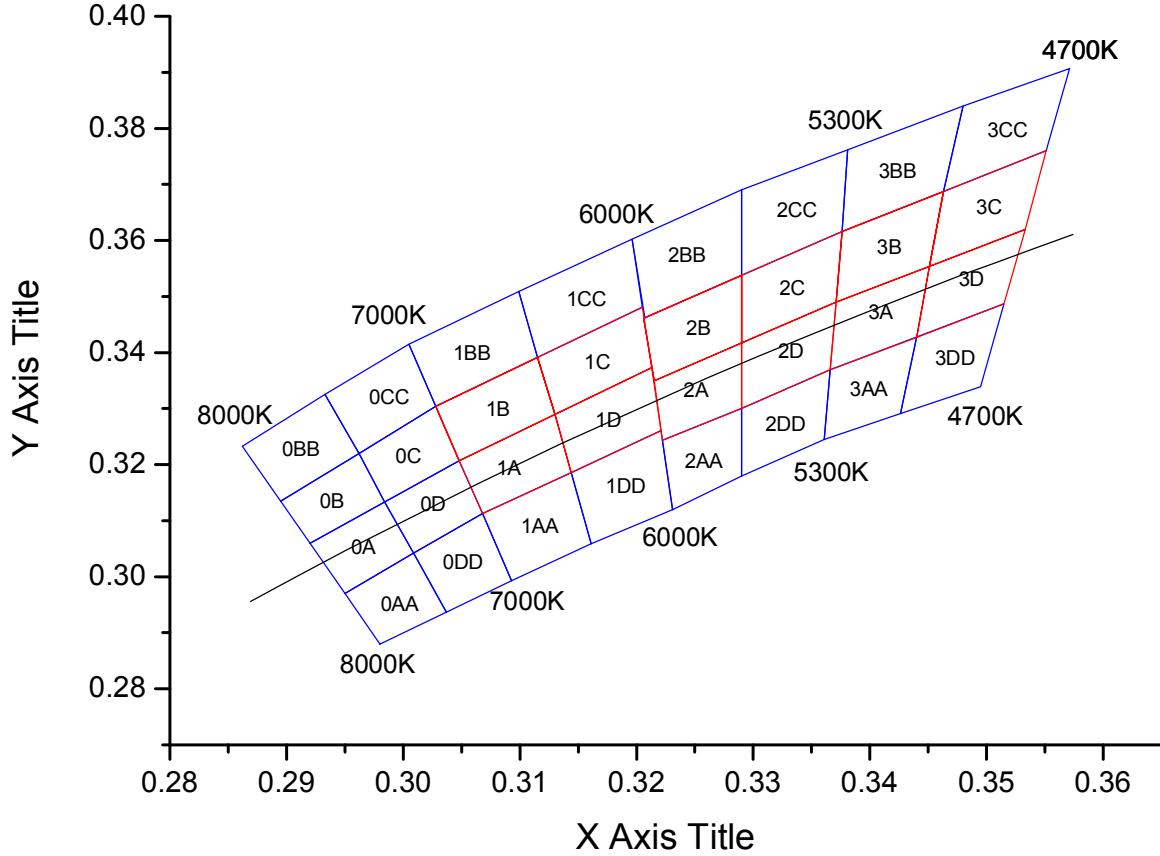

冷白 Cool White (CW)											
Region	x	y	Region	x	y	Region	x	y	Region	x	y
0A	0.295	0.297	0B	0.292	0.306	0C	0.2984	0.3133	0D	0.2984	0.3133
	0.292	0.306		0.2895	0.3135		0.2962	0.322		0.3048	0.3207
	0.2984	0.3133		0.2962	0.322		0.3028	0.3304		0.3068	0.3113
	0.3009	0.3042		0.2984	0.3133		0.3048	0.3207		0.3009	0.3042
0AA	0.298	0.288	0BB	0.2895	0.3135	0CC	0.2962	0.322	0DD	0.3037	0.2937
	0.295	0.297		0.2862	0.3233		0.2933	0.3325		0.3009	0.3042
	0.3009	0.3042		0.2933	0.3325		0.3005	0.3415		0.3068	0.3113
	0.3037	0.2937		0.2962	0.322		0.3028	0.3304		0.3093	0.2993
1A	0.3048	0.3207	1B	0.3028	0.3304	1C	0.3115	0.3391	1D	0.313	0.329
	0.313	0.329		0.3115	0.3391		0.3205	0.3481		0.3213	0.3373
	0.3144	0.3186		0.313	0.329		0.3213	0.3373		0.3221	0.3261
	0.3068	0.3113		0.3048	0.3207		0.313	0.329		0.3144	0.3186

1AA	0.3093	0.2993	1BB	0.3005	0.3415	1CC	0.3099	0.3509	1DD	0.3161	0.3059
	0.3068	0.3113		0.3099	0.3509		0.3196	0.3602		0.3144	0.3186
	0.3144	0.3186		0.3115	0.3391		0.3205	0.3481		0.3221	0.3261
	0.3161	0.3059		0.3028	0.3304		0.3115	0.3391		0.3231	0.312
2A	0.3215	0.335	2B	0.3206	0.3461	2C	0.329	0.3538	2D	0.329	0.3417
	0.329	0.3417		0.329	0.3538		0.3376	0.3616		0.3371	0.349
	0.329	0.33		0.329	0.3417		0.3371	0.349		0.3366	0.3369
	0.3222	0.3243		0.3215	0.335		0.329	0.3417		0.329	0.33
2AA	0.3231	0.312	2BB	0.3196	0.3602	2CC	0.329	0.369	2DD	0.329	0.318
	0.3222	0.3243		0.329	0.369		0.3381	0.3762		0.329	0.33
	0.329	0.33		0.329	0.3538		0.3376	0.3616		0.3366	0.3369
	0.329	0.318		0.3206	0.3461		0.329	0.3538		0.3361	0.3245
3A	0.3371	0.349	3B	0.3376	0.3616	3C	0.3463	0.3687	3D	0.3451	0.3554
	0.3451	0.3554		0.3463	0.3687		0.3551	0.376		0.3533	0.362
	0.344	0.3427		0.3451	0.3554		0.3533	0.362		0.3515	0.3487
	0.3366	0.3369		0.3371	0.349		0.3451	0.3554		0.344	0.3427
3AA	0.3361	0.3245	3BB	0.3381	0.3762	3CC	0.348	0.384	3DD	0.3426	0.3291
	0.3366	0.3369		0.348	0.384		0.3571	0.3907		0.344	0.3428
	0.344	0.3428		0.3463	0.3687		0.3551	0.376		0.3515	0.3487
	0.3426	0.3291		0.3376	0.3616		0.3463	0.3687		0.3495	0.3339

# 典型特性曲线

## Typical Characteristics Curves

伏安特性曲线  
Volt-Ampere Characteristic

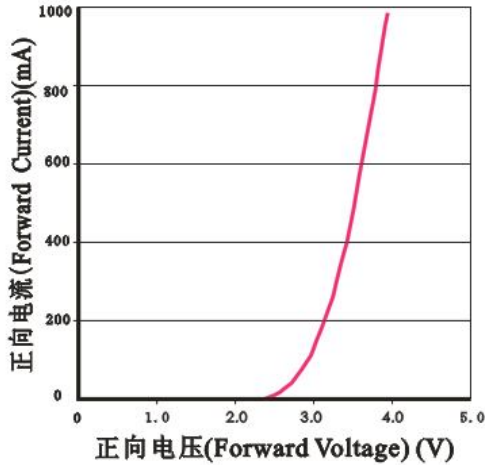

降额曲线  
Forward Current Derating Curve

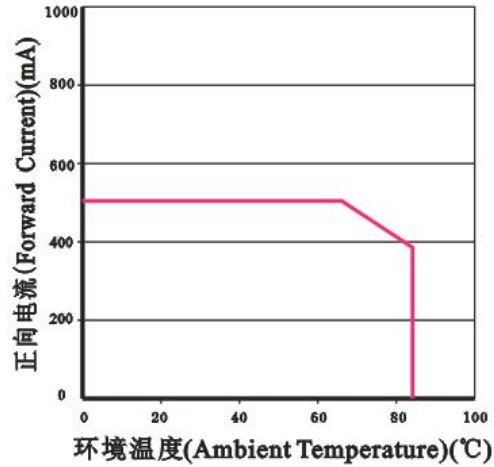

发光强度随时间变化特性曲线  
Luminous Intensity VS. Time

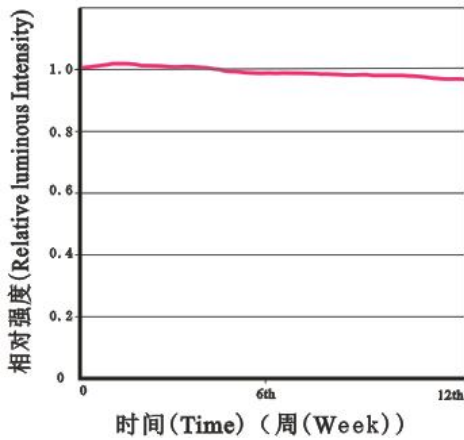

相对发光强度随电流变化曲线  
Relative Luminous Intensity VS. Forward Current

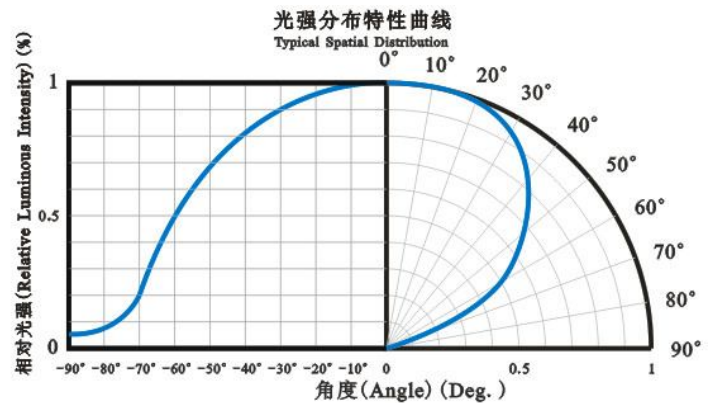
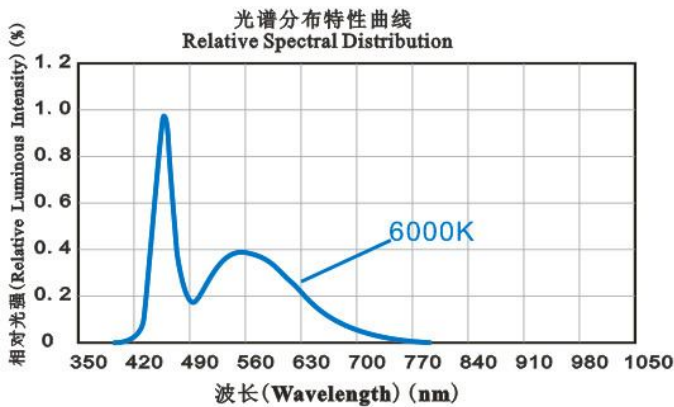
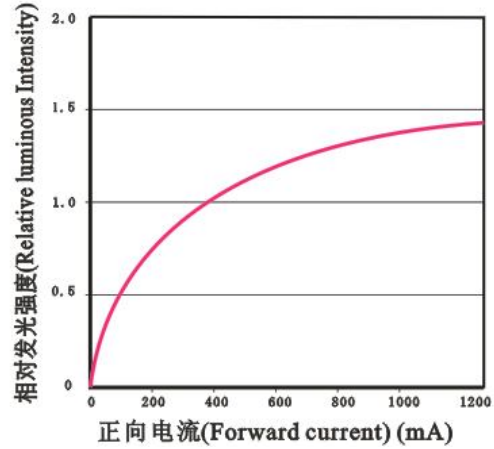

## 可靠性试验

### Reliability Test Items And Conditions

实验项目 Test Items	参考标准 Reference	实验条件 Test Conditions	时间 Time	样品数 Quantity	判据 Criterion
冷热冲击 Thermal Shock	MIL-STD-202G	-40°C(30min)←→100°C(30min)	循环 200 次 200 cycles	22	0/22
湿热循环 Temperature And Humidity Cyclic	JEITA ED-4701 200 203	-10°C~65°C , 0%~90%RH 24hrs./1cycle	循环 10 次 10 cycles	22	0/22
高温储存 High Temperature Storage	JEITA ED-4701 200 201	Ta=100°C	1000h	22	0/22
低温储存 Low Temperature Storage	JEITA ED-4701 200 202	Ta=-40°C	1000h	22	0/22
高温高湿储存 High Temperature High Humidity Storage	JEITA ED-4701 100 103	Ta=60°C, RH=90%	1000h	22	0/22
高温寿命 High Temperature Life Test	JESD22-A108D	Ta=80°C I <sub>F</sub> =350mA	1000h	22	0/22
常温寿命试验 Life Test	JESD22-A108D	Ta=25°C I <sub>F</sub> =350mA	1000h	22	0/22
耐焊接热 Resistance to Soldering Heat	GB/T 4937, II, 2.2&2.3	Tsol*=(240±5)°C 10secs	2 次 2 times	22	0/22

#### \* 失效判断标准 Criteria For Judging Damage

测试项目 Test Items	符号 Symbol	测试条件 Test Conditions	判定标准 Criteria For Judging Damage
正向电压 Forward Voltage	V <sub>F</sub>	I <sub>F</sub> = I <sub>FT</sub>	初始值±10% Initial Data±10%
反向电流 Reverse Current	I <sub>R</sub>	V <sub>R</sub> = 5V	I <sub>R</sub> ≤10μA
光通量 Luminous Flux	Φ <sub>V</sub>	I <sub>F</sub> = I <sub>FT</sub>	平均 Φ <sub>V</sub> 衰减≤30%, 单个 Φ <sub>V</sub> 衰减≤50% Average I <sub>V</sub> degradation≤30%; Single LED I <sub>V</sub> degradation≤50%
耐焊接热 Resistance to Soldering Heat			材料无内部裂痕、无材料间爆裂、剥离、无死灯。 Material without internal cracks, no material between stripped, no deaded light.

\* 注: T<sub>sol</sub>-锡液温度 \* Note: T<sub>sol</sub>-Temperature of tin liquid.



# 包装 (1)

## Packaging (1)

### 载带 Carrier Tape

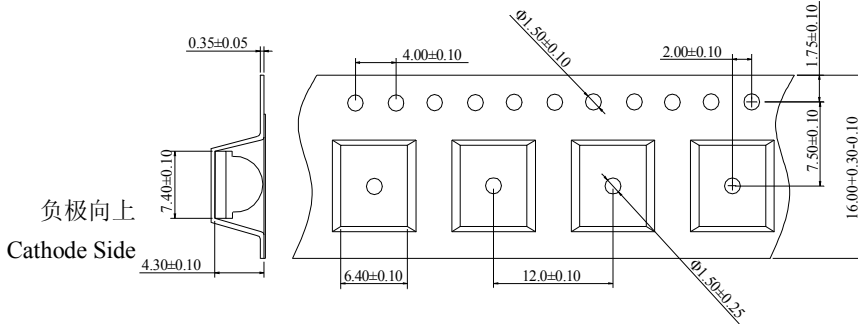

单位: mm, 未注公差:  $\pm 0.1$  mm

All dimensions in mm, tolerances unless mentioned is  $\pm 0.1$  mm.

### 编带细节 Details Of Carrier Tape

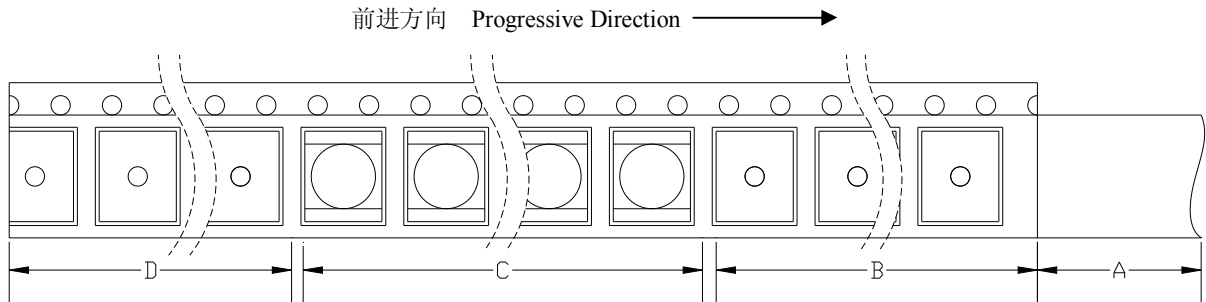

A: 盖带, 300 mm; B: 引导, 空带, 200mm; C: 编载产品 1200 只; D: 尾部, 空带, 200mm

A: Top Cover Tape, 300mm; B: Leader, Empty, 200mm; C: 1200 Lamps Loaded; D: Tail, Empty, 200mm.

### 带盘 Reel Dimension

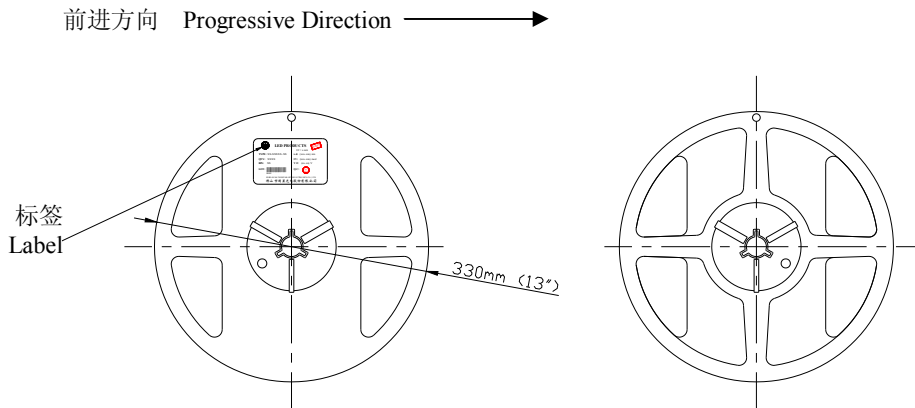

标签 Label

330mm (13")

## 包装 (2)

### Packaging (2)

#### 防潮抗静电包装 Moisture Proof and Anti-Electrostatic Foil Bag

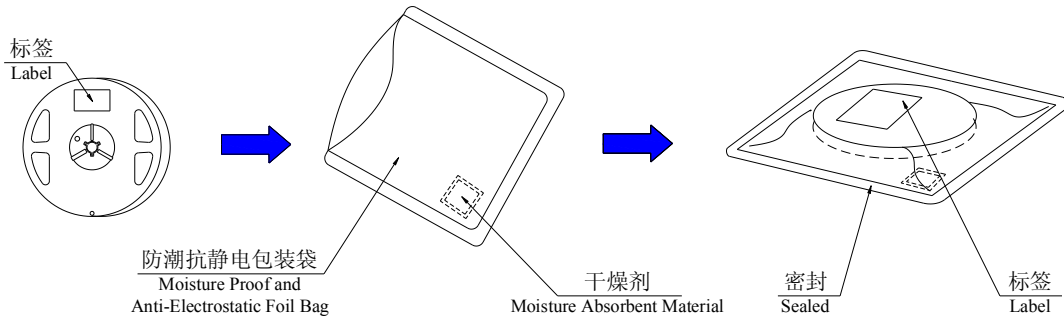

#### 外包装箱 Cardboard Box

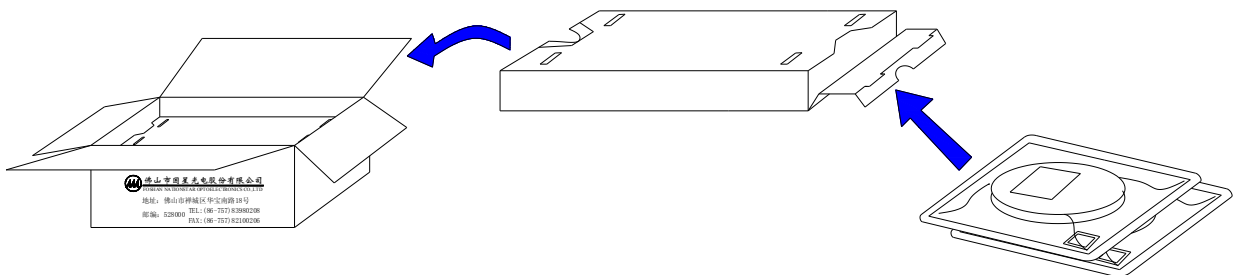

#### 标签说明 Label Explanation

Part No: 产品型号 Type  
Bin: 分档 Rank  
Qty: 数量 Quantity  
Lot No: 批号 Lot Number  
 $I_F$ : 测试电流 Testing Current  
 $\Phi_v$ : 光通量 Flux  
 $V_F$ : 正向电压范围 Forward Voltage Range  
 $T_c$ : 色温段 Color Temperature

	<b>产品名称 大功率LED</b>	
国星光电	Product name High Power LED	
Part No. <u>FP-6070XW-AFX</u>	Lot No. <u>XXMXXXXX</u>	
$I_F$ <u>XXX</u> mA	Bin <u>XXX</u>	Qty. <u>XXXX</u> pcs
$\Phi_v$ <u>XXX-XXX</u> lm		
$V_F$ <u>XX-XX</u> V	Product Code <u>XXXXXXX</u>	
$T_c$ <u>XXXX-XXXX</u> K	佛山市国星光电股份有限公司	
http://www.nationstar.com Foshan Nationstar Opto-electronics Co.,LTD		



## 焊接指导 (1)

### Guideline for Soldering (1)

- 回流焊接：推荐使用以下无铅回流焊接温度图进行。

**Reflow Soldering:** Use the conditions shown in the under Figure of Pb-Free Reflow Soldering.

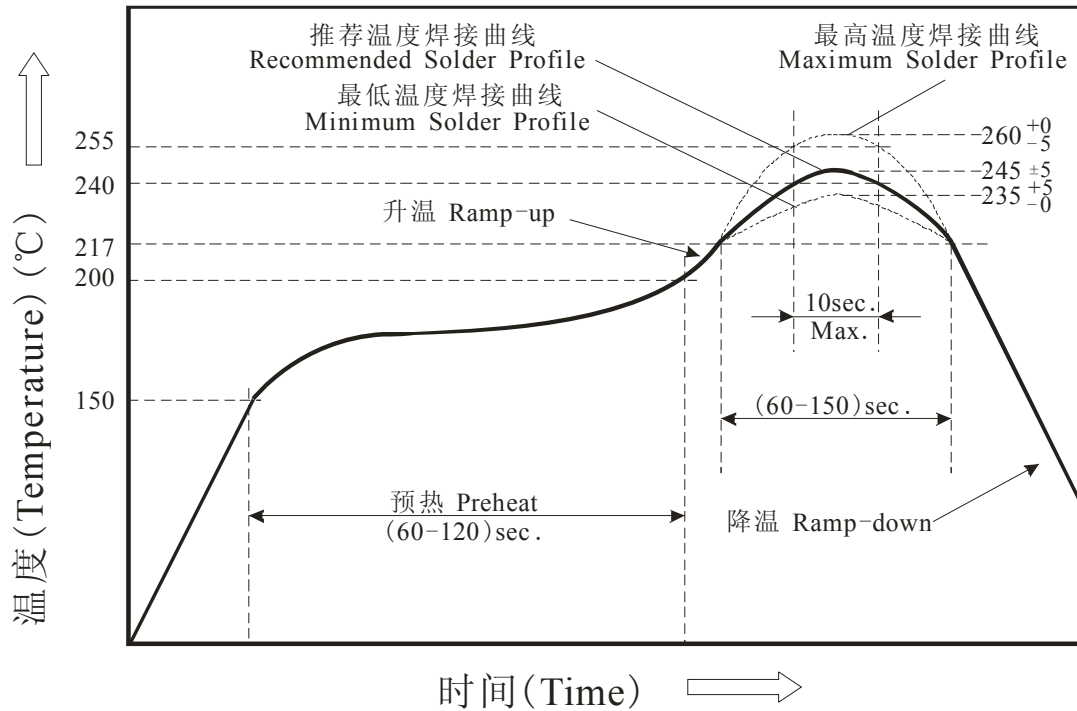

- 回流焊接最多只能进行两次。  
Reflow soldering should not be done more than two times.
- 在回流焊接升温过程中，请不要对 LED 施加任何压力。  
Stress on the LEDs should be avoided during heating in soldering process.
- 在焊接完成后，待产品温度下降到室温之后，再进行其他处理。  
After soldering, do not deal with the product before its temperature drop down to room temperature.

## 焊接指导 (2)

### Guideline for Soldering (2)

#### 2. 清洗:

##### Cleaning

在焊接后推荐使用酒精进行清洗，在温度不高于 30℃ 的条件下持续 3 分钟，不高于 50℃ 的条件下持续 30 秒。使用其他类似溶剂清洗前，请先确认使用的溶剂不会对 LED 的封装和环氧树脂部分造成损伤。

超声波清洗也是有效的方法，一般最大功率不应超过 300W，否则可能对 LED 造成损伤。请根据具体的情况预先测试清洗条件是否会对 LED 造成损伤。

It is recommended that alcohol be used as a solvent for cleaning after soldering. Cleaning is to go under 30°C for 3 minutes or 50°C for 30 seconds. When using other solvents, it should be confirmed beforehand whether the solvents will dissolve the package and the resin or not.

Ultrasonic cleaning is also an effective way for cleaning. But the influence of Ultrasonic cleaning on LED depends on factors such as ultrasonic power. Generally, the ultrasonic power should not be higher than 300W. Before cleaning, a pre-test should be done to confirm whether any damage to LEDs will occur.

- \* **注意:** 此一般指导原则并不适用于所有 PCB 设计和焊接设备的配置。具体工艺受到诸多因素的影响，请根据特定的PCB设计和焊接设备来确定焊接方案。
- \* **Note:** This general guideline may not apply to all PCB designs and configurations of all soldering equipment. The technics in practice is influenced by many factors, it should be specialized base on the PCB designs and configurations of the soldering equipment..

## 使用注意事项 (1)

### Precautions (1)

#### 1. 贮存:

##### Storage

- 本产品使用密封防潮抗静电袋包装, 并附有干燥剂, 未开封的产品有一年的保存时间。

Moisture proof and anti-electrostatic package with moisture absorbent material is used, to keep moisture to a minimum.

- 开封前, 产品须存放在温度不高于 30°C, 湿度不高于 60%RH 的环境中。

Before opening the package, the product should be kept at 30°C or less and humidity less than 60% RH, and be used within a year.

- 开封后, 产品须存放在温度不高于 30°C, 湿度不高于 10%RH 的环境中, 且应该在 24 小时 (1 天) 内使用完。建议工作环境为温度不高于 30°C, 湿度不高于 60%RH。

After opening the package, the product should be stored at 30°C or less and humidity less than 10%RH, and be soldered within 24 hours (1 day). It is recommended that the product be operated at the workshop condition of 30°C or less and humidity less than 60%RH.

- 对于尚未焊接的 LED, 如果吸湿剂或包装失效, 或者产品没有符合以上有效存储条件, 烘焙可以起到一定的性能恢复效果。烘焙条件: (80±5) °C, 持续 24 小时。

If the moisture absorbent material has fade away or the LEDs have exceeded the storage time, baking treatment should be performed based on the following condition: (80±5)°C for 24 hours.

#### 2. 静电:

##### Static Electricity

静电和电涌会导致产品特性发生改变, 例如正向电压降低等, 如果情况严重甚至会损毁产品。所以在使用时必须采取有效的防静电措施。

所有相关的设备和机器都应该正确接地, 同时必须采取其他防止静电和电涌的措施。

使用防静电手环, 防静电垫子, 防静电工作服、工作鞋、手套, 防静电容器, 都是有效的防止静电和电涌的措施。

Static electricity or surge voltage damages the LEDs. Damaged LEDs will show some unusual characteristics such as the forward voltage becomes lower, or the LEDs do not light at the low current., even not light.

All devices, equipment and machinery must be properly grounded. At the same time, it is recommended that wrist bands or anti-electrostatic gloves, anti-electrostatic containers be used when dealing with the LEDs.

## 使用注意事项 (2)

### Precautions (2)

#### 3. 设计建议:

##### Design Consideration

设计电路时, 通过 LED 的电流不能超过规定的最大值, 同时, 还需使用保护电阻, 否则, 微小的电压变化将会引起较大的电流变化, 可能导致产品损毁。

建议使用以下 (A) 电路, 该电路能够很好的调节通过每个 LED 的电流; 不推荐使用 (B) 电路, 该电路在持续的电压驱动下, LED 的正向电压 ( $V_F$ ) 发生变化, 电流会随之而发生变化, 可能使某些 LED 承受高于规定的电流值。

In designing a circuit, the current through each LED must not exceed the absolute maximum rating specified for each LED. In the meanwhile, resistors for protection should be applied, otherwise slight voltage shift will cause big current change, burn out may happen.

It is recommended to use Circuit (A) which regulates the current flowing through each LED rather than Circuit (B). When driving LEDs with a constant voltage in Circuit (B), the current through the LEDs may vary due to the variation in Forward Voltage ( $V_F$ ) of the LEDs. In the worst case, some LED may be subjected to stresses in excess of the Absolute Maximum Rating.

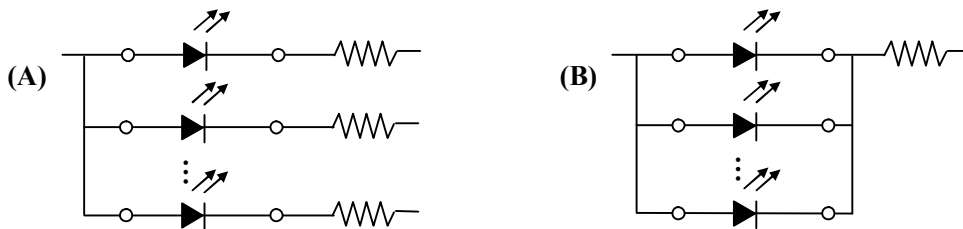

LED 的特性容易因为自身的发热和环境的温度的改变而发生改变。温度的升高会降低 LED 的发光效率、影响发光颜色等, 所以在设计时应充分考虑散热的问题。

Thermal Design is paramount importance because heat generation may result in the Characteristics decline, such as brightness decreased, Color changed and so on. Please consider the heat generation of the LEDs when making the system design.

## 使用注意事项 (3)

### Precautions (3)

#### 4. 其他事项:

##### Others

直接用手拿取产品不但会污染透镜表面,也可能由于静电等因素导致产品性能的改变。过度压力会导致产品发生形变甚至损毁,特别是当产品处于高温状态下,应避免对产品施加过度压力。

When handling the LEDs, touching the lens with bare hands will not only contaminate its surface, but also affect on its optical characters. Excessive force to the product might result in catastrophic failure of the LEDs. For this reason, please do not put excessive stress on LEDs, especially when the LEDs are heated such as during Reflow Soldering.

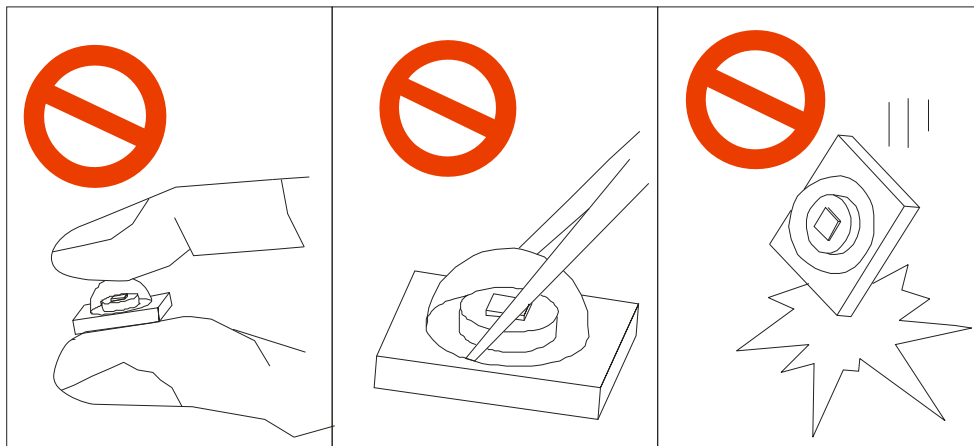

LED 的透镜相当脆弱,请勿用坚硬、尖锐的物体刮、擦透镜部分,避免造成透镜损坏或脱落。在用镊子夹取产品的时候也应当小心注意。

The lens of the product is fragile, so please avoid scratch or friction over the lens surface. While handling the product with tweezers, do not hold by the lens, be careful.

#### 5. 眼睛保护忠告:

##### Safety Advice For Human Eyes

LED 发光时,请勿直视发光光源,特别是对于一些光强较高的 LED,强光可能伤害你的眼睛。

Viewing direct to the light emitting center of the LEDs, especially those of great Luminous Intensity, will cause great hazard to human eyes. Please be careful.

444 佛山市国星光电股份有限公司  
FOSHAN NATIONSTAR OPTOELECTRONICS CO., LTD

地址: 佛山市禅城区华宝南路 18 号

电话 (Tel): (0757) 83985604, 83985605, 83985607

Add: NO.18 South Huabao Rd, Foshan, Guangdong China

传真 (Fax): (0757) 82100221, 82100223

邮编 (Zip): 528000

<http://www.nationstar.com>